



CONFIDENCE IS EVERYTHING.™

World Leader of In-Rack, Audio, Video, Data Monitoring, and Closed Captioning Solutions

AMP V Series

- AMP1A-VTR2
- AMP1-V2DA
- AMP2-VSDA

Digital/Analog Audio Speaker Monitors

User Guide

Part Number 821021, Revision A

© 2010 Wohler Technologies, Inc. and PANORAMA. All rights reserved.

This publication is protected by federal copyright law. No part of this publication may be copied or distributed, stored in a retrieval system, or translated into any human or computer language in any form or by any means electronic, mechanical, manual, magnetic, or otherwise, or disclosed to third parties without the express written permission of Wohler Technologies.

Reproduction

Licensed users and authorized distributors of Wohler Technologies, Inc. products may copy this document for use with Wohler Technologies, Inc. products provided that the copyright notice above is included in all reproductions.

Customer Support

Wohler Technologies, Inc.
31055 Huntwood Avenue
Hayward, CA 94544
www.wohler.com

Phone: 510-870-0810
FAX: 510-870-0811
US Toll Free: 1-888-596-4537
(1-888-5-WOHLER)
Web: www.wohler.com
Sales: sales@wohler.com
Support: support@wohler.com

Disclaimers

Even though Wohler Technologies, Inc. has tested its equipment and software, and reviewed the documentation, Wohler Technologies, Inc. makes no warranty or representation, either express or implied, with respect to software, documentation, their quality, performance, merchantability, or fitness for a particular purpose.

Wohler Technologies, Inc. reserves the right to change or improve our products at any time and without notice.

In no event will Wohler Technologies, Inc. be liable for direct, indirect, special, incidental, or consequential damages resulting from any defect in the hardware, software, or its documentation, even if advised of the possibility of such damages.

Some states do not allow the exclusion or limitation for incidental or consequential damages, so the above exclusion or limitation may not apply to you.

Printing

This document is intended to be printed on a duplex printer, such that the copy appears on both sides of each page. This ensures that all new chapters start on a right-facing page.

This document looks best when printed on a color printer since some images may be indistinct when printed on a black and white printer.

Other Technologies and Products

Dolby, Dolby Digital, Dolby D, and Dolby E are registered trademark of Dolby Laboratories, Inc.

Microsoft Windows, and Internet Explorer are registered trademarks of Microsoft Corporation.

Last Update

January 12, 2010

AMP V Series User Guide

Introduction

Overview

The AMP V Series monitors are audio monitors capable of audibly monitoring up to four analog source channels through an internal stereo speaker system while simultaneously visually monitoring all four channels of the selected source via four high-resolution LED bar graph level meters.

Topics

Topics	Page
Introduction	1
Safety Instructions	2
Installation Recommendations	3
Description	4
Features	5
Specifications	6
Audio Amplifier and Speaker Configuration	7
Front Panel Controls	8
Rear Panel Connectors	13
Line Level Calibration Instructions	17
Internal Switch Settings	20
Technical Functional Overview	24

Safety Instructions

1. Read, keep, and follow all of these instructions; heed all warnings.
2. Do not use this equipment near water.
3. Use only a dry cloth to clean the equipment.
4. Do not block any ventilation openings. Install only in accordance with the instructions in the section entitled, "[Installation Recommendations](#)" on [page 3](#).
5. Do not install near any heat source such as a radiator, heat register, amplifier, or stove.
6. Do not expose the equipment to rain or moisture.
7. Do not attempt to plug the unit into a two-blade outlet (with only two prongs of equal width).

IMPORTANT: By design, these monitors will only plug into a three-prong outlet for your safety. If the plug does not fit into your outlet, contact an electrician to replace the obsolete outlet.

8. Protect the power cord from being walked on or pinched, particularly at plug's source on the equipment and at the socket.
9. Use only the attachments/accessories specified by the manufacturer.
10. Unplug the equipment during lightning storms or when unused for long periods of time.
11. Refer all servicing to qualified service personnel. Servicing will be required under all of the following conditions:
 - The equipment has been damaged in any way, such as when the power-supply cord or plug is damaged.
 - Liquid had been spilled or objects have fallen onto the equipment.
 - The equipment has been exposed to rain or moisture.
 - The equipment does not operate normally.
 - The equipment has been dropped.

Installation Recommendations

Unpacking

Unpack the AMP V Series monitor from the shipping container and inspect all components for shipping damage. If you find any damage, notify the shipping carrier for claims adjustments.

Compare the shipping box contents to the packing slip. Contact Wohler's customer support personnel about any discrepancies. (Wohler's contact information is on the copyright page ii, of this manual).

Heat Dissipation

The ambient temperature inside the mounting enclosure should not exceed 40° Celsius (104° Fahrenheit). Adjacent devices can be rack mounted (or stacked) in proximity to the unit if the above temperature is not exceeded. Allow a 1RU (1.75" / 44.45mm) space above and below the unit for air circulation.

Important: The heat generated by the power amplifiers, power supplies, and other components is vented by slots in the side of the unit. Therefore, as a safety precaution, we advise you to be sure to allow proper ventilation on both sides of the unit.

Rack Mounting

You should install the monitor into a standard 19" rack and requires a maximum of 3RU of rack space (the 2RU unit, plus 1RU above and below). Also, install it as close to the operator's direct viewing angle as possible as LCD screens can appear to display anomalies outside this viewing angle.

Cable Connections

Wohler recommends Belden 8281 or Belden 1694A cables for analog video signals and Belden 9451 cables for analog audio signals.

Power

Each unit comes with a standard 24VDC/3.0A internal power supply and connects an A/C mains power source (65W, 100 to 240 VAC, 50/60Hz) to the IEC connector provided on the rear panel of the unit.

Electrostatic Discharge (ESD)

As with most electronic equipment, static discharges can damage components within the unit. Take precautions to ensure your installation environment is not subject to ESD.

Description

In addition to the four high-resolution LED bar graph level meters, the AMP V Series monitors also provide two banks of four buttons on the front panel which are used to independently assign from one to four (summed) channels to each of the two (left and right) speaker channels. Features for these two models include a stereo volume control and balance control, power indication LED, headphone output, and a stereo analog output on two balanced XLR connectors of the channels assigned to the left and right speaker channels. Output limiter circuits are incorporated to protect the speakers, and extensive magnetic shielding allows placement immediately adjacent to video monitors with no color impurities. Wohler Technologies proprietary three-LED stereo phase indication feature allows monitoring of phase relationships of the selected channels assigned to the left and right speaker channels. The four LED bar graph level meters offer selectable Input Reference Level, Display Mode, Peak Hold, Ballistics. Phase Correlation and alternate scales are available as options.

Features

- 98 dB SPL at two feet
- Excellent high frequency response for positive detection of background whine and noise
- Audible and visual indication of phase/polarity problems
- Thorough magnetic shielding for placement next to video monitors
- Four high-resolution tri-color bargraph level meters:
 - Selectable input reference level (0, +4, +6, or +8 dBu)
 - Selectable display mode (VU Only, VU/PPM, or PPM Only)
 - Selectable peak hold (Manual, 3-Second, 10-Second, or Off)
 - Selectable ballistics (Type I, Type II, DIN 45406, or SSRT)
 - Selectable alternate bar graph scales (Extended VU is standard) Alternative AES, VU, BBC, NORDIC, and DIN scale labels are available as an option.
 - Selectable phase correlation (labels available as option F).
- Two banks of four push buttons for assigning single or summed channels to the left and right speakers
- Digital/analog source selection via front panel toggle switch
- Headphone output
- Power indication LED

Specifications

Table 1-1 lists the specifications for the AMP V Series monitors.

Table 1-1 AMP V Series Monitors Specifications

Specifications	AMP1-V2DA	AMP1-VTR2	AMP2-VSDA
Level Meter Type	26-Segment		53-Segment
	Tri-Color (red, amber, green) LED Bar Graph		
Segment Size	.158" x .04" (4.0132 mm x 1.016 mm)		
Peak Hold (selectable)	Manual, 3 sec, 10 sec, or off		
Dynamic Range	62 dB		65 dB
Scale	+12 to -50 db		+ 16 to -50 dB
Bar Graph Scales	VU, Ext, VU, BBC, Nordic, or Din		
Midscale Resolution			1 dB
Input Connectors	4 Analog (Phoenix) 2 AES (BNC)	8 Analog (Phoenix)	4 Analog (XLR) 2 AES (XLR/BNC) 1 SDI (BNC)
Analog Input Impedance	Phoenix: 200k Ω balanced	Phoenix: 90k Ω balanced	XLR: 70k Ω balanced
Digital Input Impedance	BNC: 75 Ω unbalanced	—	BNC: 75 Ω unbalanced XLR: 110 Ω balanced
Input Level for Maximum Output (Volume Full On)	0 dBv balanced; -10 dB unbalanced		
Peak Acoustic Output (@ 2 ft.)	98 dB SPL		104 dB SPL
Frequency Response, Sixth Octave	80 Hz to 16 kHz \pm 7 dB (-10 dB @ 50 Hz, 22kHz)		80 Hz to 16 kHz \pm 5 dB (-10 dB @ 40 Hz, 20kHz)
Power Output			
RMS Each Side (4 Ω)	10 W transient/5 W continuous		14 W transient/ 10 W continuous
RMS Bass (4 Ω)	20 W transient/10 W continuous		35 W transient/ 25 W continuous
Distortion, Electrical	< 0.15% at any level below input threshold		
Distortion, Acoustic	8% or less at worst case frequencies above 180 Hz including cabinet resonance; typically less than 2%		6% or less at worst case frequencies above 180 Hz including cabinet resonance; typically less than 1.5%
Hum and Noise	Better than -68 dB below full output		
Magnetic Shielding	< 1 Gauss any adjacent surface		< 0.8 Gauss any adjacent surface
Power Consumption	35W		45 W
AC Mains Input	100 to 240 V AC, 50 to 60 Hz Universal		
Weight	10 lbs. (4.53 kg)		18 lbs. (8.2 kg)
Dimensions (H x W x D)	1.7" H x 19" W x 12" D (43 mm x 483 mm x 305 mm)		3.5" H x 19" W x 12" D (89mm x 483mm x 305mm)

Audio Amplifier and Speaker Configuration

Audio Amplifiers

All AMP V Series models contain high performance speakers driven by three power amplifiers; two amplifier/driver combinations handle midrange and high frequency information in the left and right (stereo) speaker channels, while the third amplifier channel sums the left and right channel information below the 500 Hz crossover point in the woofer (bass) speaker(s). Note that the woofer channel is not a dedicated LFE or center channel.

Speaker Configuration

The 1U rack size AMP1 Series products are configured with two speakers (left and right) to reproduce mid- and high-range audio frequencies (in stereo), but feature two woofer speakers to reproduce the summed (combined) low-range audio frequencies from the left and right speaker input channels. It should be noted that both woofer speakers, which are wired in series, are driven from one woofer speaker channel, and are not stereo. See the simplified diagram below for a block diagram of the AMP1 Series audio amplifier/speaker configuration. The 2RU AMP2 is similar, except the side speakers are larger and has only one woofer.

Figure 1–1 Audio Amplifier and Speaker Configuration

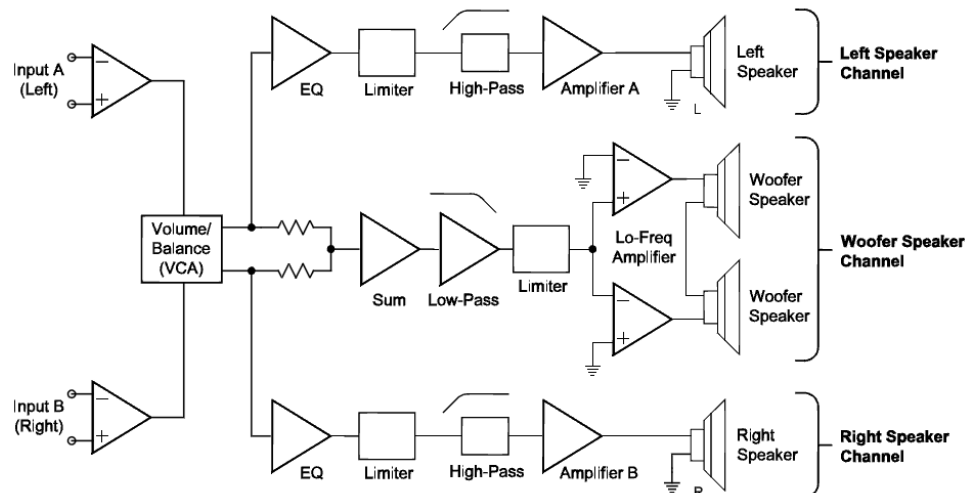

Front Panel Controls

Common Controls

- **Speakers:** The AMP1 V Series monitors feature two mid-range speakers (left and right) and two woofer speakers (one woofer in the AMP2 models). Combinations handle midrange and high frequency information in the left and right (stereo) speaker channels, while the third channel reproduces and sums the left and right channel information below the 500 Hz crossover point in the woofer (bass) speaker. Note that the woofer channel is not a dedicated LFE (subwoofer) or center channel.
- **Headphones:** This jack accepts a standard 1/4" phone type stereo plug. When you plug in headphones, the internal or external speakers will mute.
- **Source or Left Speaker/Right Speaker (Assign):** Use the left bank of four buttons to assign one to four of the four available channels for monitoring from the left speaker channel. Use the right bank of four buttons to assign one to four of the four available channels for monitoring from the right speaker channel. Channel buttons toggle on/off and will light up blue to indicate they are selected. Operation for each bank of four buttons is as follows:
 - **Single Channel Select:** Press and release a single channel button to select that channel (and deselect any previous selection). Pressing and releasing the selected channel button again will deselect it.
 - **Multi-Channel Select (Summing):** Press and hold down a desired channel button, then press other channel buttons to add (sum) additional channels (or press any again to deselect). Release all buttons to accept the selection set. When multiple channels are selected, pressing and holding an already selected channel button will allow further modification to the selection set. Releasing all buttons accepts the new selection set. Pressing and immediately releasing an already selected channel button will select only it and deselect all other channel selections.

If the user presses a previously selected (lighted) channel button, but then decides not to make any changes to the selection set, the user should keep the button depressed for at least 1.5 seconds

before releasing it. This will preserve the current selection set as though the button was never pushed.

- **Level Meters:** Audio levels for the four selected source channels are displayed via these four tri-color LED bargraph meters. The four bar graph meters display levels for the digital or analog sources as selected by the **Analog/Digital** source select switch. All bar graph LED segments are of the tri-color type (green, amber, red) and are user adjustable for reference level, display mode, peak hold, PPM ballistics, alternate bar graphscales, and phase correlation via DIP switches on the rear panel and inside the unit.
- **Volume (Rotary Knob):** This controls the loudness of the audio reproduced by the internal speakers or connected headphone. Clock-wise rotation of this control increases the loudness of the monitored audio in the speakers or headphones.
- **Power (LED):** This LED glows green to indicate the unit is connected to mains power and an operation voltage is present.
- **Phase (LEDs):** These three LEDs indicate the instantaneous and average phase (polarity) conditions between the two signals in the channel pair (or downmix) assigned to the left and right speaker channels. The two smaller LEDs labeled Φ show instantaneous (fast) phase relationships in the signal. The larger LED labeled **AVG** will indicate the average phase condition.
 - $\Phi+$: The green fast LED glows (or blinks) for in-phase signals.
 - $\Phi-$: The amber fast LED glows (or blinks) for out-of-phase signals.
 - The large **AVG** LED indicates the average phase condition by glowing green for in-phase signals, or red for out-of-phase signals.

In general, observing the **AVG** LED alone is sufficient for proper phase monitoring. While it is normal for stereo signals to contain some intermittent instantaneous out-of-phase and in-phase conditions (fast LEDs), a steady red glow of the **AVG** LED indicates an out-of-phase alarm condition.

- **Brightness (Potentiometer):** This control is recessed into the front panel and can be accessed using a small screwdriver. Turning it clockwise will increase the relative brightness of all bar graph display LED segments.

- **Balance** (Rotary Knob): This adjusts the volume balance between the left and right speakers or headphones with the left and right bass frequencies (summed together and reproduced in the woofer channel) also responding to the balanced control.

Example: If an audio signal of a voice speaking English is fed to the left (A) input and a voice speaking Spanish is fed to the right (B) input, then the left speaker channel will reproduce the midrange and high-range frequencies of the English speaking voice, the right speaker channel will reproduce the midrange and high-range frequencies of the Spanish speaking voice, and the woofer speaker channel will reproduce the summed (combined) low-ranged of both voices.

AMP1A-VTR2-Specific Controls

Figure 1–2

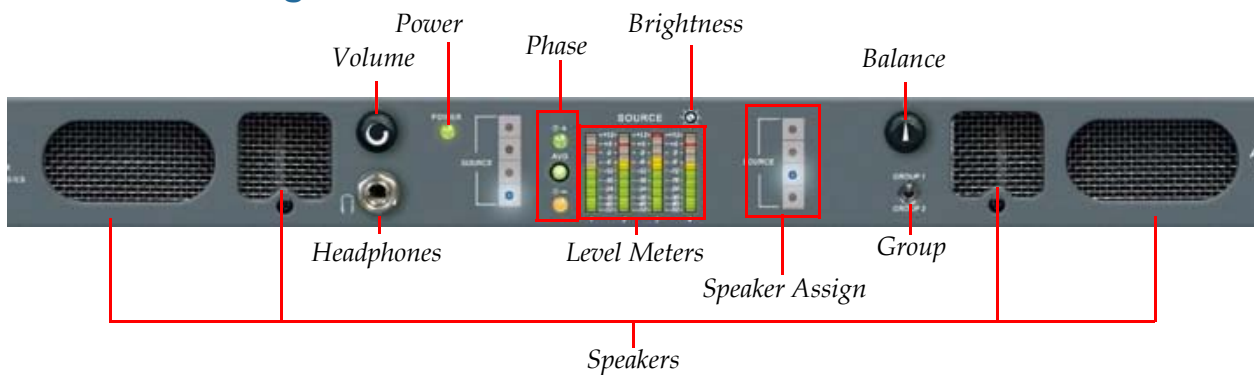

Group Select (Toggle Switch): On the AMP1A-VTR2 model, this switch selects between the two groups (**Group 1** or **Group 2**) of four channels as input on the rear panel. It is from the selected group of four channels that the **Source Speaker Assign** channel buttons are used to independently assign channels to the right and left speakers.

AMP2-VSDA-Specific Controls

Figure 1–4 AMP2-VSDA Front Panel

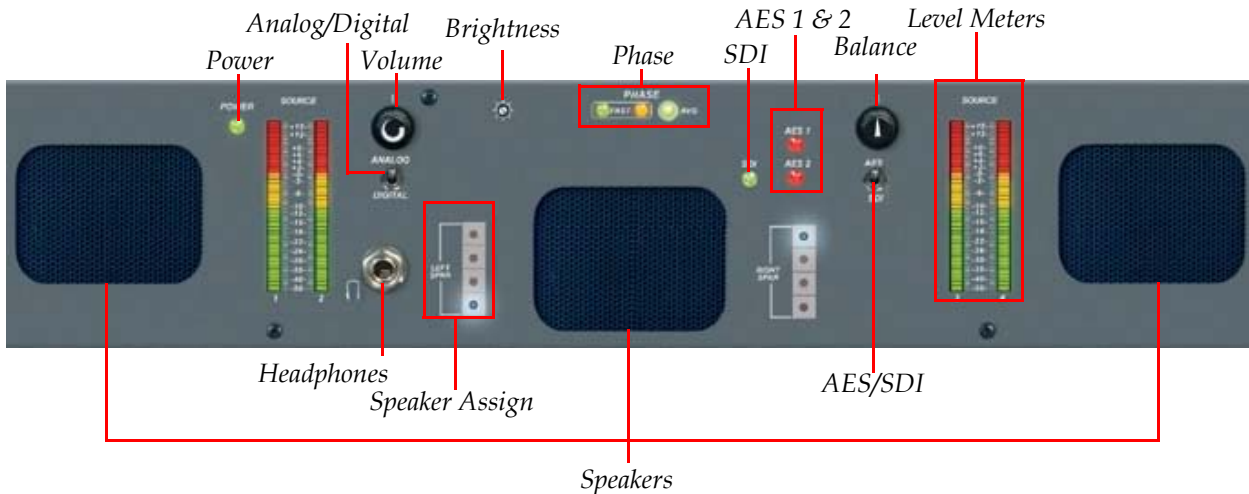

- **Analog/Digital Select** (Toggle Switch): This two position switch selects between two primary input sources, analog or digital. When this toggle switch is set to analog, the unit will monitor the signals as input on the rear panel **Analog In** phoenix connectors. When this toggle switch is set to digital, the unit will monitor whichever source is selected by the **AES/SDI** switch.
- **AES/SDI** (Toggle Switch): This two position toggle switch allows the operator to choose between the two digital input sources; SDI or AES. When this toggle switch is set to AES, the unit will monitor the AES signals as input on the **AES In** BNC or XLR connectors (**In 1** and **In 2**) on the rear panel. When this toggle switch is set to SDI, the unit will de-embed and monitor the SDI signals as input on the **SDI In** BNC connector on the rear panel.
- **AES (1 & 2, LEDs)**: These two bi-color green/red LEDs (AES1 and AES2) indicate the input presence and status of the two AES input signals. Each LED glows green as long as a valid AES/EBU digital datastream for the associated input channel is being received. Each LED glows red to indicate errors in signal reception or data errors (if the data has been tagged as inappropriate for conversion to analog by having the validity bit set). These LEDs function whether or not the AES digital signals are selected for monitoring through the unit.
- **SDI** (LED): This bi-color (green/red) LED, labeled SDI, glows green as long as a valid SDI digital datastream is being received. It glows red if TSR errors are present in the signal. If there is no SDI

signal present the LED will be unlit. This LED functions whether or not the SDI digital signal is selected for monitoring through the unit.

Rear Panel Connectors

Common Connectors Descriptions

- **Power:** Attach a standard IEC-320 power cord between this connector and mains power (100 - 250VAC, 50/60 Hz). The front panel Power LED will glow green to indicate operating voltages are present.
- **Selected Output** (Two, 3-Pin XLR Male): These connectors are analog outputs of the monitor mix as selected by the left and right **Speaker Assign** channel buttons and source switches on the front panel. The left connector outputs the left channel (Chan. A (L)) and the right connector outputs the right channel (Chan. A (L)). Both connectors are configured for low impedance connections and the output signals are not affected by the volume/balance controls or headphone mute. For XLR connector pin-out information in [Figure 1-5](#) below.

Figure 1-5 Selected Output 3-Pin Male XLRs

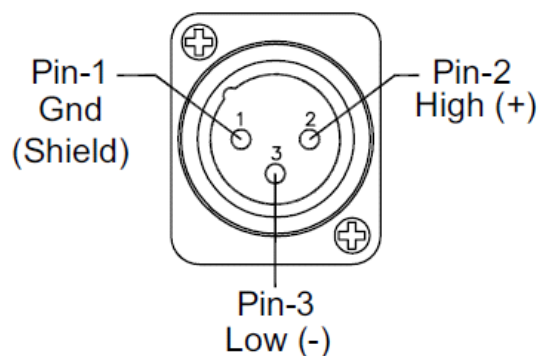

Line Level Calibration (Six-Position DIP Switch): This DIP switch sets the line level calibration, reference level, and PPM/VU display mode for the level meter LED bar graph displays on the front panel. The pin-out is silk-screened onto the the rear panel.

AMP1-VTR2-Specific Connectors

Figure 1–6 AMP1-VTR2 Rear Panel

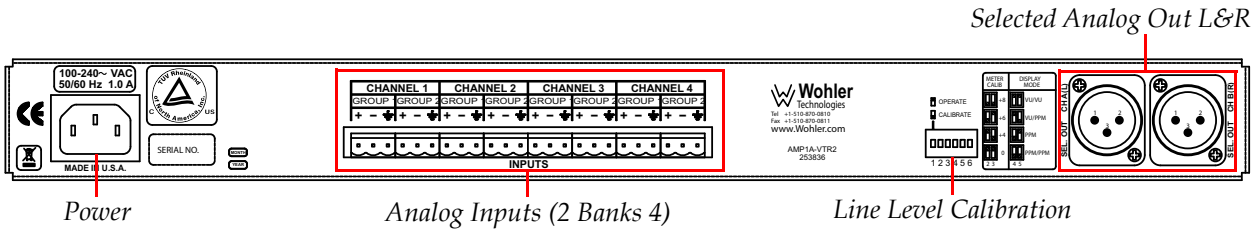

- Analog Input** (3-Pin Phoenix Male, Channels 1 through 4, Group 1 or 2): These connectors accept standard analog audio signals and are configured for balanced 90K Ω connections. The banks (groups) of input connectors are interleaved and either group of four inputs (Group 1 or Group 2) may be selected for monitoring using the two-position **Group** select switch on the front panel. Channel input numbers are silk-screened above the connectors (Channel 1, 2, 3, 4) and correspond to the numbers available for selection by the left and right **Speaker Assign** channel buttons on the front panel. Connector pinout information is silk-screened just above each connector.

AMP1-V2DA-Specific Connectors

Figure 1–7 AMP1-V2DA Rear Panel

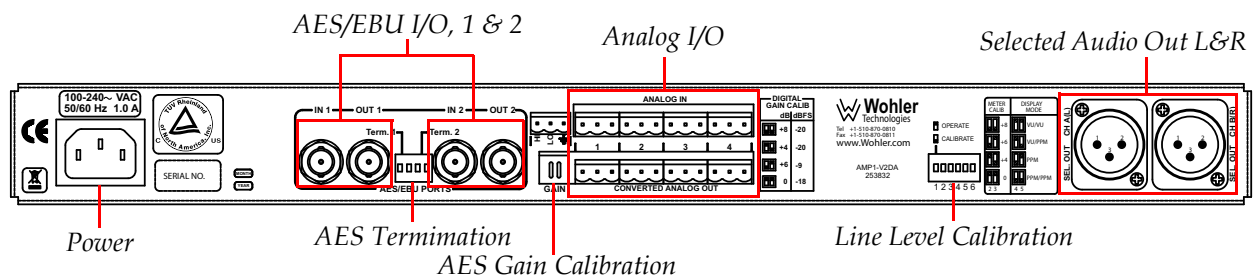

- AES In** (1 & 2, on BNC): These input connectors receive industry standard, unbalanced (75 Ω) AES signals. Note that the unit will monitor the AES inputs only when the **Analog/Digital** source select switch is set to **Digital**.
- AES Out** (1 and 2, on BNC): These two unbalanced (75 Ω) loop-through connectors each output a copy of the signal entering the corresponding AES input connector.

- **AES Termination** (Four-Position DIP Switch): This DIP switch sets the termination for the AES inputs. If an AES input channel is fed to downstream equipment, the associated DIP switch must be in the up position (unterminated). If no downstream equipment is connected, the switch must be in the down position (terminated). See [Figure 1-8](#) for details.

Figure 1-8 AES Termination DIP Switch Settings

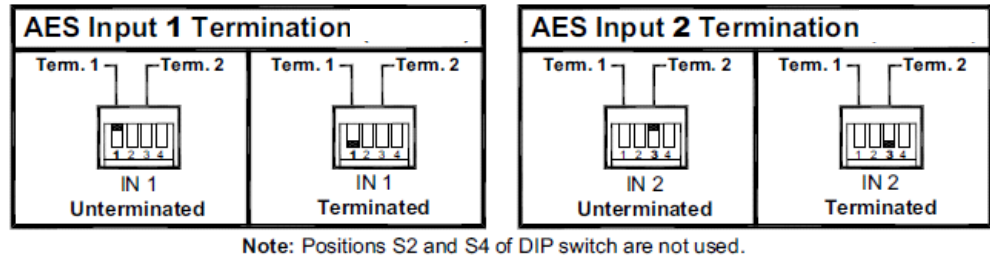

- **Analog Input** (3-Pin Phoenix Male, Channels 1 through 4): These connectors accept standard analog audio signals and are configured for balanced 90K Ω connections. The banks (groups) of input connectors are interleaved and either group of four inputs (Group 1 or Group 2) may be selected for monitoring using the two-position **Group** select switch on the front panel. Channel input numbers are silk-screened above the connectors (Channel 1, 2, 3, 4) and correspond to the numbers available for selection by the left and right **Speaker Assign** channel buttons on the front panel. Connector pinout information is silk-screened just above each connector.
- **AES Gain Calibration** (Two-Position DIP Switch): This DIP switch calibrates the AES analog level that corresponds to a given digital input value. The factory setting is +4 dB (analog) = -20 dBFS (digital).

Figure 1-9 AES Gain Calibration DIP Switch Settings

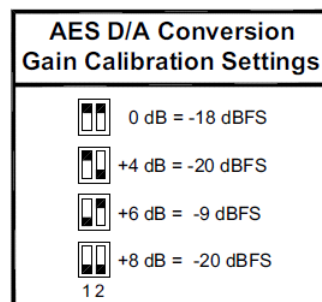

- **Converted Analog Out** (Converted from AES Inputs) (Phoenix, 3-Pin Male, Outputs 1 through 4): These connectors output standard, balanced analog signals converted from the AES digital inputs (but not the analog inputs) and are not affected by the position of the **Analog/Digital** source select switch.

AMP2-VSDA-Specific Connectors

Figure 1–10 AMP2-VSDA Rear Panel

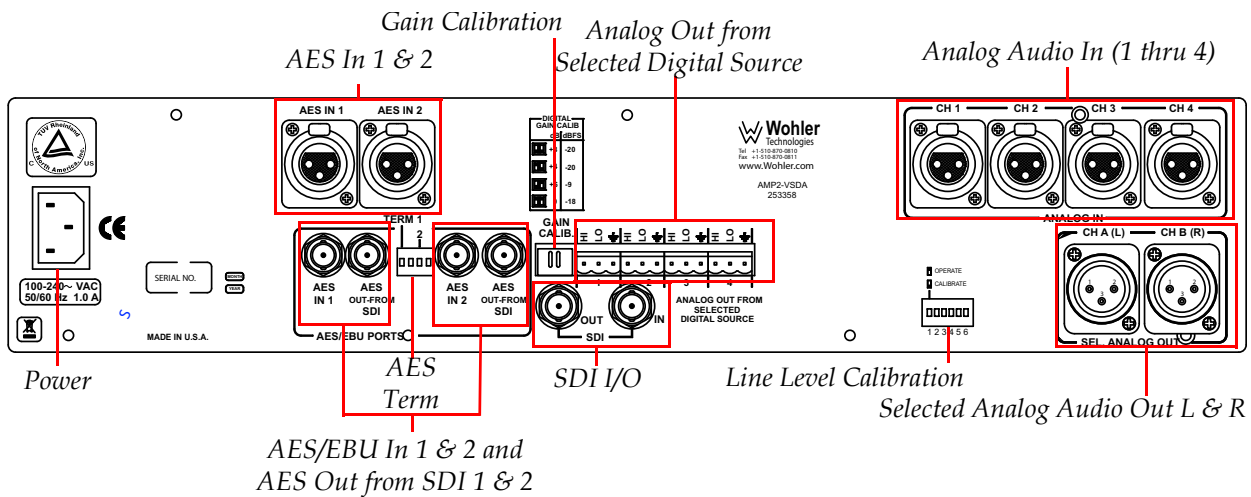

- **AES In** (1 & 2, on XLR-F): These input connectors receive industry standard, balanced (110 Ω) AES signals. Note that the unit will monitor the AES inputs only when the **Analog/Digital** source select switch is set to **Digital** and the **AES/SDI** source select switch is set to **AES**.

Important: Do not input signals simultaneously to the AES BNC connectors and the AES XLR connectors of the same channel (i.e., **BNC AES In 1** and **XLR AES In 1**).

- **AES In** (1 & 2, on BNC): These input connectors receive industry standard, unbalanced (75Ω) AES signals. Note that the unit will monitor the AES inputs only when the **Analog/Digital** source select switch is set to **Digital**.

Important: Do not input signals simultaneously to the AES BNC connectors and the AES XLR connectors of the same channel (i.e., **BNC AES In 1** and **XLR AES In 1**).











- **AES Out from SDI** (1 and 2, on BNC): These two unbalanced (75 Ω) loop-through connectors each output a copy of the de-embedded audio from the SDI input.
- **AES Termination** (Four-Position DIP Switch): This DIP switch sets the termination for the AES inputs. If an AES input channel is fed to downstream equipment, the associated DIP switch must be in the up position (unterminated). If no downstream equipment is connected, the switch must be in the down position (terminated). See [Figure 1-8](#) for details.
- **SDI In and Out** (BNC-F): This unbalanced (75 Ω) input connector receives standard SD-SDI signals. The unit monitors Subgroup 1 (Channels 1 and 2) and Subgroup 2 (Channels 3 and 4) of SDI Group 1. Note that the unit will monitor the SDI input only when the **Analog/Digital** source select switch is set to **Digital**, and the **AES/SDI** digital source select switch is set to **SDI**.

The unbalanced (75 Ω) **SDI Out** loop-through connector outputs a reclocked copy of the signal entering the **SDI In** connector.

- **Analog Out from Selected Digital Source** (3-Pin Phoenix Male, Outputs 1 through 4): The balanced (75 Ω) connectors output analog signals converted from the selected digital inputs (but not the analog inputs). These outputs are *not* affected by the position of the **Analog/Digital** source select switch. The pin-out is silk-screened onto the rear panel.

Line Level Calibration Instructions

Figure 1-11 Calibration Settings

AMP Series Level Meter Rear Panel DIP Switch Settings		
Meter Calibration	Reference Level	Display Mode
<div style="display: flex; justify-content: space-between; width: 100%;"> 1 x </div>  <div style="display: flex; justify-content: space-between; width: 100%;"> 1 2 3 4 5 6 </div> <p>Calibrate</p>  <p>Operate</p>	<div style="display: flex; justify-content: space-between; width: 100%;"> 2 3 x </div>  <div style="display: flex; justify-content: space-between; width: 100%;"> 1 2 3 4 5 6 </div> <p>+8 dB</p>  <p>+6 dB</p>  <p>+4 dB</p>  <p>0 dB</p>	<div style="display: flex; justify-content: space-between; width: 100%;"> 4 5 x </div>  <p>VU Only</p>  <p>VU-PPM Floating Segment</p>  <p>PPM Only</p>  <p>PPM-PPM Floating Segment</p>

AMP V Series User Guide
Line Level Calibration Instructions

- Note:** Position 6 of the DIP Switch is not used.
- Note:** For more accurate indication of signal levels, meters are tuned to effect a “rounding” function, which occurs between the thresholds of any two bar graph segments. This means the level meter zero (0) LED sigment will turn on at one-half the smallest spacing between LED segments (mid-scale resolution) before that segment’s scale indication.

Table 1–2 Meter Segment Rounding Offsets

Scale	26-Segment Bar Graphs	53-Segment Bar Graphs
Analog, Extended VU	.5 dB	.5 dB
Digital		
Nordic		
DIN		
BBC	.125 dB	.25 dB
VU		

Example: Using the Extended VU scale, a meter calibrated for a +4 dBu nominal level will actually turn the zero LED segment of the level meter on at +3.5 dBu (and so all segments will turn on at 0.5 dBu before that segment’s scale indication).

Line Level (Auto) Meter Calibration

The unit is calibrated at the factory prior to shipping for +4 dBU = -20 dBFS = 0dB on the meter. To recalibrate:

1. Turn on the power.
2. Apply the desired reference level (nominal 0) signal to all channels.
3. Make sure the Reference Level DIP sections (2 and 3) are set to the nearest level of the input signal being applied for calibration (i.e., 0, +4, +6 or +8). The user should make sure that the signal applied to all four channels is within +/- 4 dB of the reference level selected by DIP switch sections 2 and 3.
4. Place DIP section 1 in the down position.
5. Wait 10 seconds. The unit will remove the previous calibration and the new calibration will be applied.

6. Place DIP section 1 in the up position and return unit to service.
7. Only one auto-calibration attempt may be made for each cycling of AC power to the unit. Once the Line Level Calibration DIP switch has been placed in the CAL position, it is necessary to cycle the power before that DIP switch will be functional again, even if a calibration attempt was unsuccessful.

If you want to calibrate again, turn off the power to the unit and repeat steps 1 through 6.

Reference Level

DIP switch sections 2 and 3 determine the Reference Level, which adjusts the level of the input signal and the resultant level displayed on the LED bargraphs. Factory setting is +4 dB. See DIP switch diagram below for settings.

Bar Graph Display Mode

DIP switch sections 4 and 5 determine how peak levels are displayed for the associated meters on the front panel.

The four possible settings are:

- VU Only,
- VU-PPM Floating Segment,
- PPM Only, and
- PPM-PPM Floating Segment.









The VU Only selection has a VU floating segment when a Peak Hold value is selected using the Internal 10-Position DIP Switch Module (see [Figure 1-12 on page 20](#)). The factory default setting is VU-PPM Floating Segment.

Internal Switch Settings

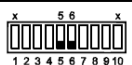
After removing the top cover, you can access DIP switches that control level meter settings and/or calibration settings.

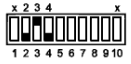
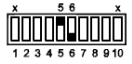
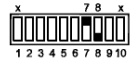
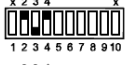
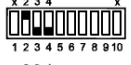
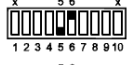
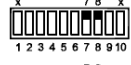
This 10-position DIP module is located on the 919174 PCB (See [Figure 1-13 on page 21](#) for the location.) Refer to [Figure 1-12](#) below for a complete list of settings and functions. (Switch positions 1 and 10 are not used and should be left at the factory set position.)

Figure 1-12 10-Position DIP Switch Settings

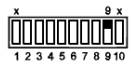
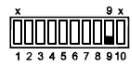
AMP Series (Analog) Level Meter Internal 10-Position DIP Switch Settings					
Scale Selection		Peak Hold (Bargraph Display)		PPM Ballistics (Bargraph Display)	
 Do Not Use	 NORDIC Scale	 Peak Hold - Manual (See Note 2)	 IEC268-10, Type 1		
 Extended VU Scale (Standard Analog)	 DIN Scale	 Peak Hold - 3 Second	 IEC268-10, Type 2		
 VU Scale	 Do Not Use	 Peak Hold - 10 Second	 DIN 45406		
 BBC Scale	 Legacy Extended VU Scale	 Peak Hold - Off	 Single Sample Rise Time (SSRT)		
Phase Correlation Display					
 PC Off		 PC On			

Scale Selection

The standard scale used on the 30-segment bar graph display for the Extended VU scale. However, if alternative scale characteristics are selected for the level meters by setting the Alternate Scale DIP switches ([Figure 1-12](#) above), it is recommended that a label with the appropriate scale be applied to the front panel LED bar graph level meters. Alternate scales include the VU, BBC, Nordic, and DIN scales. The Extended VU scale is the standard scale for all AMP V Series models. See [Figure 1-14](#) and [Figure 1-15 on page 22](#) for alternate scales. Contact Wohler Technologies for more information about Alternate Scale labels.

Figure 1-13 Internal DIP Switch Location
(PCB 919174)

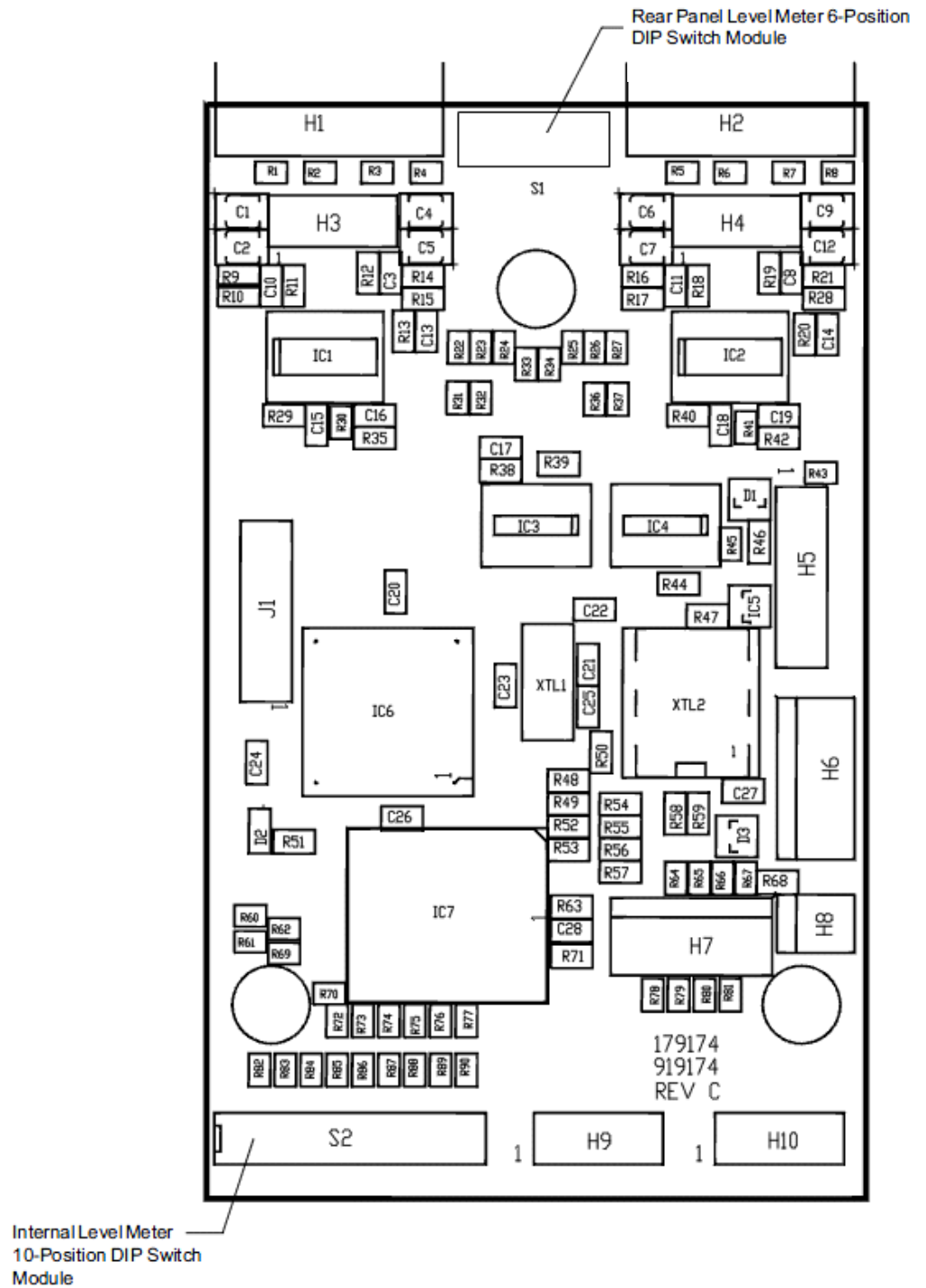

Figure 1–14 AMP2-VSDA Alternative Scales

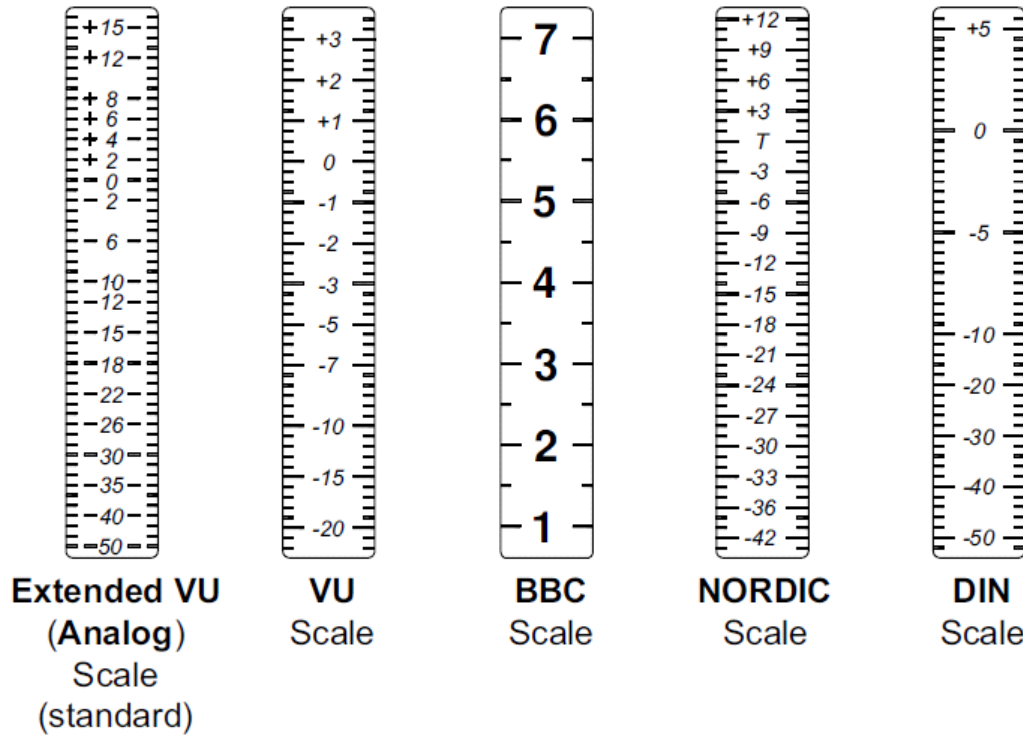
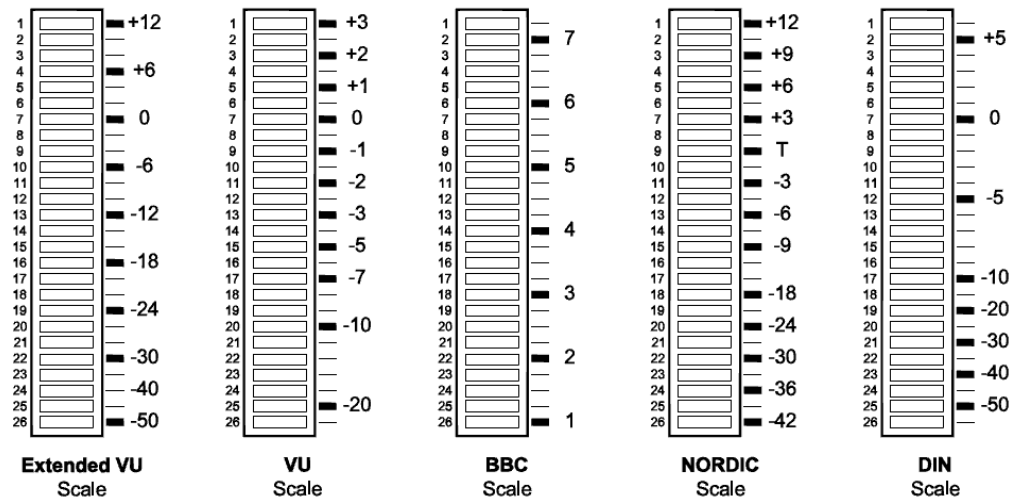

Figure 1–15 AMP1-VSDA and AMP1-VTR2 Alternative Scales



Peak Hold

The Peak Hold - Manual setting allows the bar graph display meters to indefinitely maintain the peak hold value until you reset it, either by pressing a reset button (a special option specified at time of order) or by removing power and then reapplying power to the unit (unplug/replug power cord). Contact Wohler Technologies for more information about this feature.

PPM Characteristics

The PPM characteristics determine the integration time (rise time) and return time (fall time) of the level meter. The integration time is the time it takes for the lighted segments of the level meter, after application of a 5 kHz tone at a certain reference level, to rise within a specified number of dB of that level. Return time is the time it takes for the lighted segments of the level meter to fall a certain number of dB after removal of a 5 kHz tone of a certain reference level. The PPM characteristics available for selection using DIP switch Sections 7 and 8 of the 10-position Internal DIP Switch (Figure 1-12 on page 20) are listed in Table 1-3 below.

Table 1-3 PPM Ballistics and Integration/Return Time Relationships

PPM Ballistics	Integration/Return Times
IEC268-10, Type 1	Integration (Rise) Time is 5 ms (-2 dB); Return (Fall) Time is 1.7 seconds (20 dB)
IEC268-10, Type 2	Integration (Rise) Time is 10 ms (-2 dB); Return (Fall) Time is 2.8 seconds (24 dB)
DIN 4506	Integration (Rise) Time is 5 ms (-2 dB); Return (Fall) Time is 1.5 seconds (20 dB)
Single Sample	Integration (Rise) Time is a single sample; Return (Fall) Time is 1.5 seconds (20 dB)

Phase Correlation Display

Since it is sometimes helpful to observe phase relationships between two signals being monitored, you can enable the phase correlation feature within the lower section of the existing bar graph pair in the AMP2-VSDA. This feature is enabled by setting a switch on the internal 10-position DIP switch module located internally on the PCB. See Figure 1-13 on page 21 for DIP module location, and Figure 1-16 for settings. The labels for this feature (see diagram below) can be specified

at the time of order or requested from Wohler for application to existing units.

Figure 1–16 Phase Correlation Labels

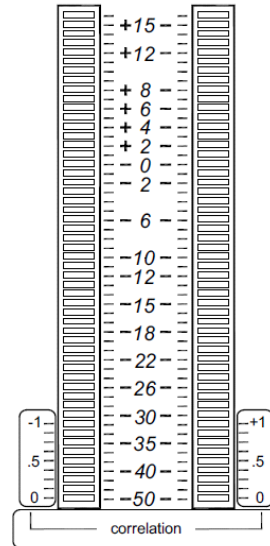

Positive amounts of correlation are indicated by an ascending amber bar in the right channel bar graph; negative correlation is shown when a red bar ascends in the left channel bar graph. While the audio level in both channels is high enough, the phase correlation indication occupies the bottom 13 segments of both bar graphs of a 30-segment stereo pair. One additional segment above the active correlation region is always off, to serve as a marker. The correlation display is visible only so long as the VU audio level is above this blank segment (fourteenth segment up on the 30-segment bar graph).

Technical Functional Overview

Figure 1-17 on page 25 through Figure 1-19 on page 27 illustrate the overall functionality of each of the AMP V Series monitors.

Figure 1–17 AMP1- V2DA Block Diagram

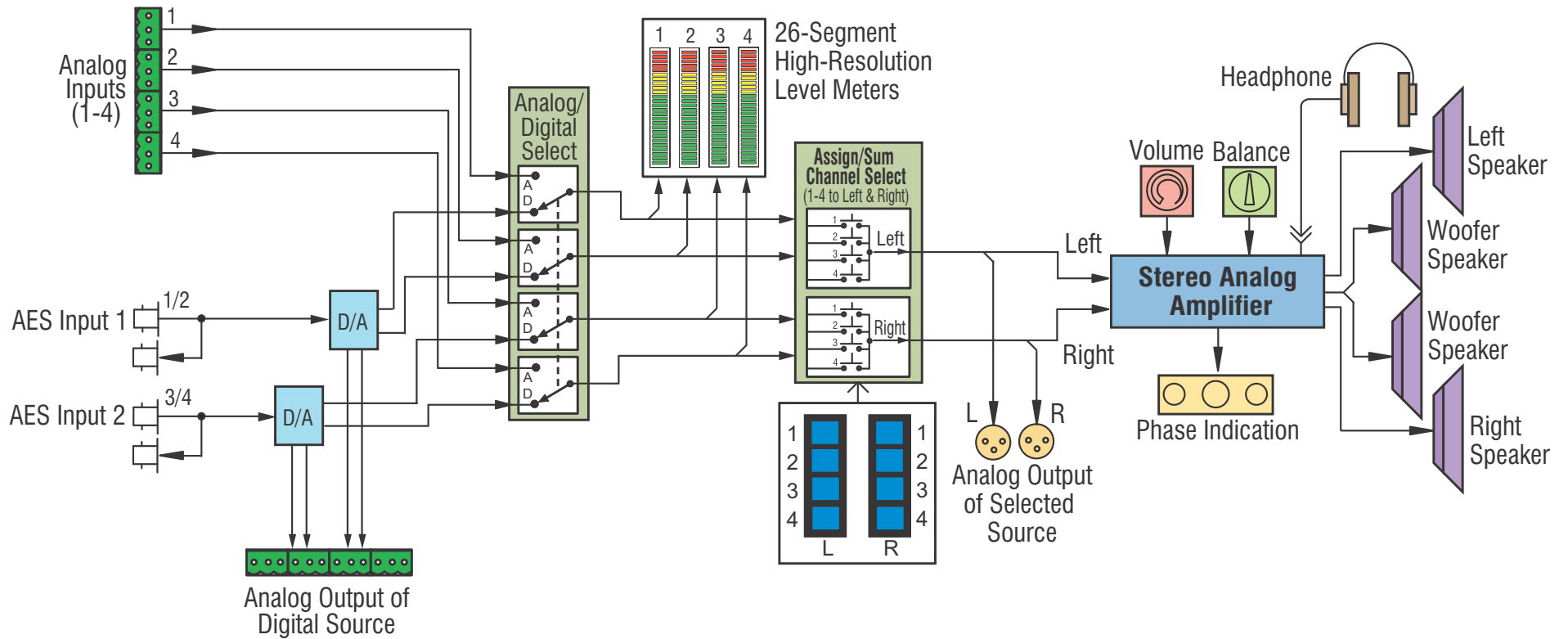

Figure 1-18 AMP2-VSDA Block Diagram

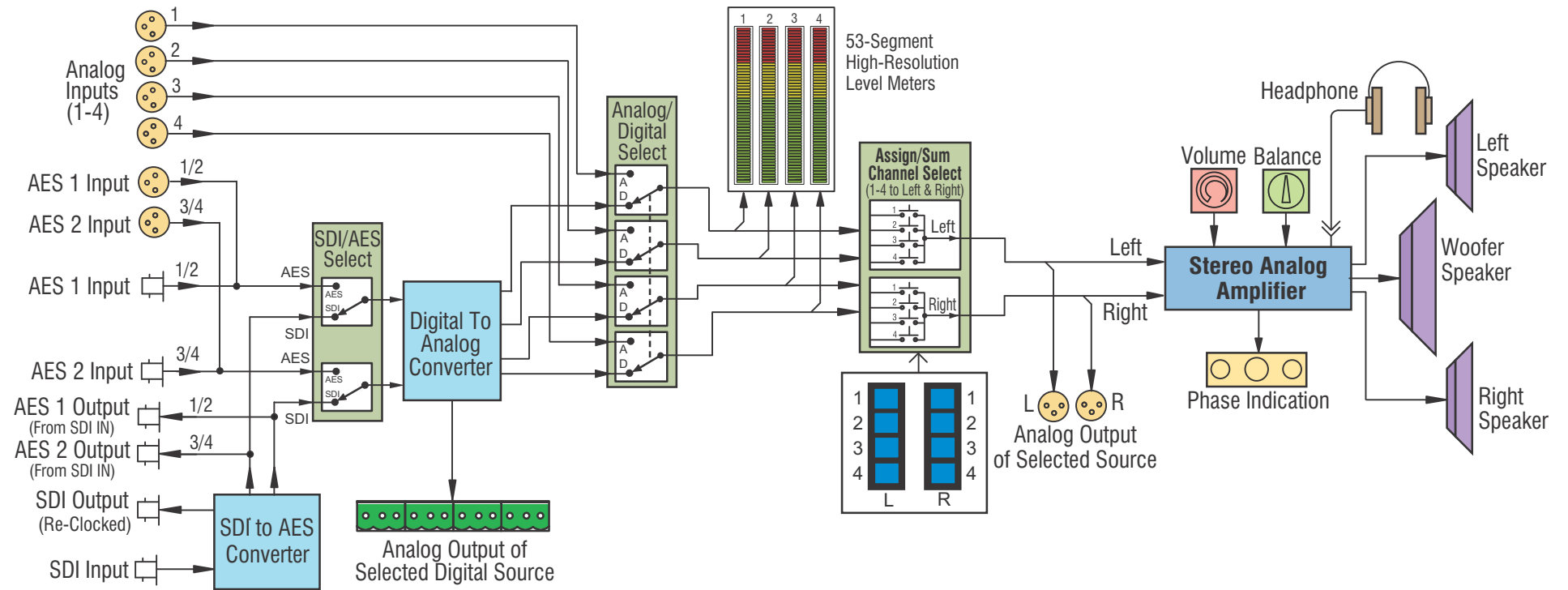

Figure 1–19 AMP2-VTR2 Block Diagram

