

The left-hand 2.4" OLED displays either video or metadata.

Description

The AMP1-16 Series monitors from Wohler Technologies are our latest solutions offering 16 channel, multi-rate 3G/HD/SD-SDI and AES audio monitoring with Dolby capability all in a slim 1RU chassis.

The AMP1-16 Series monitors represents leading edge technology and features. The audio fidelity of our most popular models have been improved with a Class-D digital amplifier system to drive the integrated midrange and low frequency speaker drivers. These units monitor 16 channels of embedded 3G/HD/SD-SDI and AES audio, while the AMP1-E16V-MD includes Dolby D and Dolby E capability. All channels can be selected for simultaneous display and concurrently monitored on an innovative OLED screen that is easily user-configured for bar graph meter look, scale, and ballistics. All popular scales are available on screen, at the touch of a button. You can route any selected signal to either the left or right, or both speakers for stereo or mono applications.

Features

All 16 channels of audio visually monitored on 16 level meters displayed in two OLED screens.

Monitoring for up to 16 channels of embedded audio in a single, multi-rate 3G/HD/SD-SDI signal.

Totally digital system architecture with high-fidelity class D amplifier

Video embedded in the 3G/HD/SD-SDI or a number of types of additional information may also be displayed on an innovative third screen. All serial audio channels are de-embedded and available on the rear panel as 8 unbalanced AES signal pairs or 8 analog channels. The system can also output a re-clocked 3G/HD/SD-SDI, allowing the unit to be racked with a series of video monitors. Additionally, it provides 3G to HD or HD to SD down-conversion output.

The operational feature set of the AMP1-16 Series monitors is unmatched! Eight hot keys provide instant access to solos, mutes, or presets. When the solo function is enabled, each selected channel is highlighted for easy identification, while all other channels remain active for visual evaluation. Power tools like loudness measurement comply with ITU-1770/1771, and delay-to-match OLED monitor and ingest process are included.

Video de-embedded from 3G/HD/SD-SDI displayed on the third screen

Stereo or mono monitoring assignment to speakers

Analog and digital surround sound system outputs, controllable from the front panel volume control

Order Part Numbers

AMP1-16V-MD: 8130-0050

AMP1-E16V-MD: 8130-0060 (Includes Dolby D/E Card)

Includes demux outputs for 8 AES pairs on unbalanced on 2 HD15 connectors

Compact 1RU system

Create and store 8 user-defined operation configurations

Monitoring for up to 16 channels of embedded audio in a single, multi-rate 3G/HD/SD-SDI signal.

Benefits

The AMP1-16 Series monitors are truly flexible systems. Integrate one and benefit from the rich feature set.

Three color OLEDs not only allow you to customize colors for easy monitoring, but also display up to 16 bar graph level meters simultaneously. The third screen can also display video or data.

Stereo phase indicator for stereo pairs

Measurement of loudness and dial norm data can be prominently displayed

Includes outputs for 8 analog channels on a balanced DB25

Re-clocked output of 3G/HD/SD-SDI and 3G to HD and HD to SD signal down conversion output

At only 1RU it gives you the power of several units with the simplicity of a single package.

Each displayed meter can feature stereo phase indication, user-defined channel labeling, and selectable scales and ballistics, such as AES, BBC, and Nordic. A custom setting allows user-defined limits and colors.

Rear Panel

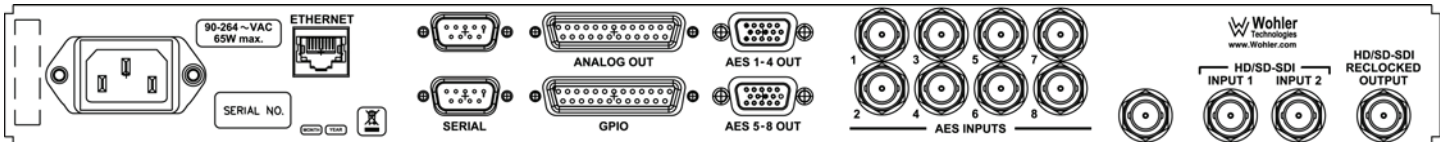

Physical Specifications

Dimensions (H x W x D)	1.75" x 19" x 11" (44.45 mm x 483 mm x 279.4 mm)
Weight	10 lbs. (4.54 kg)
Space Requirements	1RU in a standard 19" rack
Supplied Accessories	AC external power unit/cord
Optional Accessories	Dolby Card
Power Connector	Power plugs into standard U.S. outlet. Alternate power cables are available.
Power Requirements	100 to 240 V AC \pm 10%, 50/60Hz
Power Consumption	Approximately 60 W

Technical Specifications

Inputs	2 3G/HD/SD-SDI (equalized) on BNC 8 AES/EBU on unbalanced BNC 1 Ethernet on RJ-45 1 RS-232 on DB-9 1 Metadata on DB-9 (reserved for future use)
Outputs	1 3G/HD/SD-SDI (equalized) on BNC 1 Down converted Video on BNC 8 AES/EBU pairs on 2 on HD-15 8 Analog channels balanced on 1 DB-25 2 GPI on HD-37
AES Input Termination	75 Ω unbalanced, switchable
SDI Input Termination	75 Ω unbalanced
Level Meters	User-defined on the OLED display
Level Meter Scale	0 to -72 dB in 110 segments
Reference	User configurable
Level Meter Representation	Simultaneous VU and PPM, configurable
Level Meter Scales	AES • VU • Ext. VU • BBC • EBU • Nordic • DIN
Ballistics	Selectable preset and user ballistics
Midscale Resolution	1 dB
Peak Acoustic Output at 2 feet	98 dB SPL
Power Output	RMS each side (8 Ω), 6 W, 12 W peak RMS Low Freq. Drivers (4 Ω), 22 W, 40 W peak
Frequency Output	80 Hz to 20 kHz (± 5 dB) (-10 dB at 50 Hz, 22 kHz)
AES/EBU Input Sampling Rate	32 to 48 kHz, auto-detecting
Hum and Noise	Better than -68 dB below full output
Display Types	3 OLEDs
Screen Size	2.4" diagonal per screen
Native Aspect Ratio	4:3
Active Viewing Area	1.93" x 1.45" (48.96 mm x 36.72 mm) per screen
Viewing Angle	170° H, 170° V
Resolution	320 x 240 RGB pixels
Pixel Pitch	0.0605 mm x 0.1815 mm
Pixel Response	50 μ s Off-On-Off (Black to White to Black)
Luminance	200 cd/m ²
Contrast	10,000:1

Block Diagram

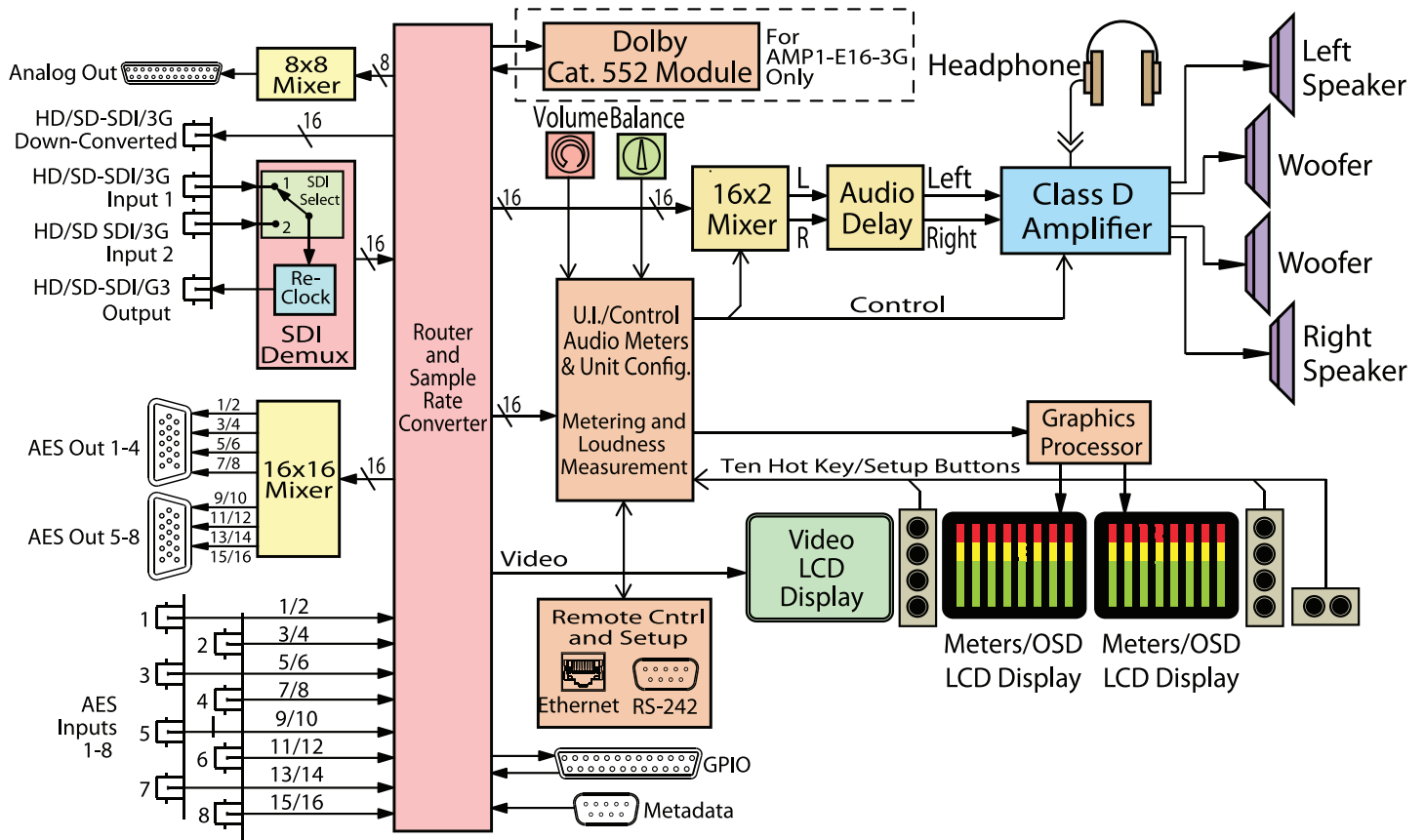

Contact

Wohler Technologies, Inc.
 Worldwide Headquarters
 31055 Huntwood Avenue
 Hayward, CA 94544 USA
 Phone: +1 510 870 0810
 Fax: +1 510 870 0811
 Email: sales@wohler.com

Wohler Technologies/Asia
 1704 Lucky Commercial Centre
 103 Des Voeux Road West
 Sheung Wan, Hong Kong
 Phone: +852 2851 8325
 Fax: +852 2850 8182
 Email: salesasia@wohler.com

Wohler Technologies/Australia
 PO Box 14
 South Hurstville
 NSW 2221, Australia
 Phone: +61 2 8005 1899
 Fax: +61 2 9547 0674
 Email: salesaustralia@wohler.com

Wohler Technologies/EMEA
 453 Stroude Road, Virginia Water
 Surrey GU25 4BU
 United Kingdom
 Phone: +44 (0) 2081 236 658
 Fax: +44 (0) 208 181 6500
 Email: salesemea@wohler.com