



Description

The AMPx-S8DA monitors are a complete exceptionally, high-quality audio monitor systems offering premium quality 8-channel analog, AES/EBU, digital multi-channel audio monitoring and conversion as well as professional level metering. These units contain 3 audiophile-quality drivers and three power amplifiers; 3 speakers and amplifiers reproduce midrange and high frequency information in stereo, while the third amp/driver combination handles summed LF information below the 500 Hz crossover point.

The AMPx-S8MDA models feature eight 53-segment high-resolution, tri-color LED level meters showing simultaneous VU and PPM for superior level-metering. The front panel features an innovative LCD display of phase/polarity relationships. Output limiter circuits are incorporated to protect the speakers, and extensive magnetic shielding allows placement immediately adjacent to video monitors with no color impurities.

The unique design provides optimally focused sound for operators in an ultra near-field (1 to 3 ft.) working environment and offers performance comparable to that of many separate monitor pairs, without the installation hassles, awkward speaker placements and “added-on” look. This provides for a higher SPL for the operator while reducing overall ambient sound and adjacent bay crosstalk. Extended HF response reveals potential problems with audio whine or hiss and electronic rather than acoustic cancellation of bass frequencies provides positive audible detection of out-of-phase (reversed polarity) audio feeds. A headphone jack is provided on the front panel that automatically mutes the speakers.

These units are ideally suited for use in space-critical environments such as TV facilities, studios, VTR bays, mobile production vehicles, satellite links and indeed, any rack mount environment where multi-channel audio monitoring is required.

Order Part Numbers

AMP1-S8DA:	8101-0030	(1RU—Analog and AES)
AMP2-S8DA:	8103-0020	(2RU—Analog and AES)
AMP1-S8MDA:	8101-0070	(1RU—Analog, AES, and HD/SD-SDI)
AMP2-S8MDA:	8103-0080	(2RU—Analog, AES, and HD/SD-SDI)

Features

Eight 53-segment tri-color LED bar graphs displaying simultaneous VU and PPM

Headphone jack (mutes speakers)

Front panel summing of any combination of up to 8 channels to the left and/or right speakers and selected

Premium quality drivers and power amplifiers

Audible indications of phase/polarity problems

Phase-correlation display of selected channels

Output limiter protected speakers

Benefits

Thorough magnetic shielding prevents interference from nearby equipment.

Electronic cancellation provides detection of out-of-phase (reversed polarity) audio feeds.

Excellent frequency response and low distortion

Focused sound, reduces adjacent bay crosstalk

Ultra near-field offers exceptional monitoring performance.

Small rack space requirements make them perfectly suited for use in space-critical environments

Rear Panels

AMP1-S8MDA

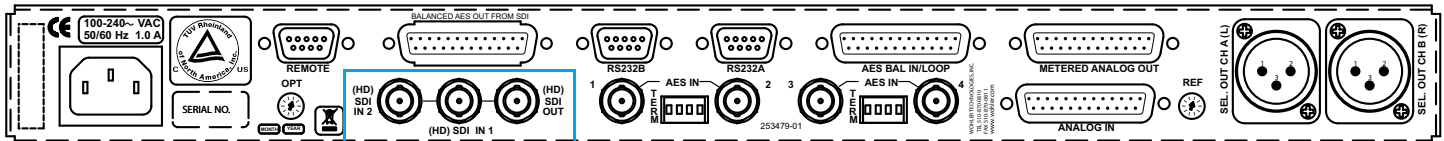

HD/SD-SDI I/O is only available on the MDA model.

AMP2-S8MDA

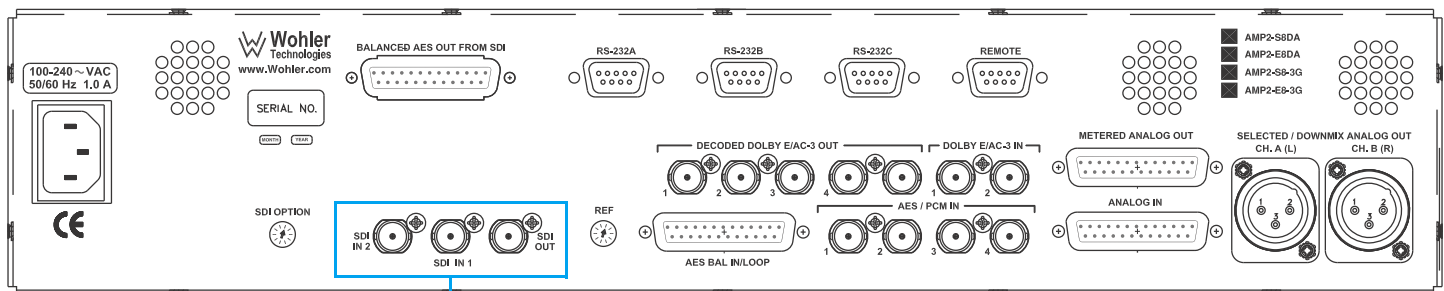

HD/SD-SDI I/O is only available on the MDA model.

Physical Specifications

Dimensions (H x W x D)	1RU Units: 1.75" x 19" x 11" (4.5 mm x 483 mm x 279 mm) 2RU Units: 3.5" x 19" x 12.5" (89 x 483 x 317.5 mm)
Shipping weight	1 RU Units: 13 lbs (5.9 kg) 2 RU Units: 22 lbs (9.98 kg)
Space requirements	1 or 2 RU in a standard 19" rack
Supplied accessories	AC external power unit/cord
Power Connector	Attached external power unit plugs into standard U.S. outlet. Alternate power cables are available.
Power Requirements	Power to the unit is 100 to 240 V AC \pm 10%, 50/60Hz.
Power Consumption	60 W

Technical Specifications

Inputs	8 balanced analog (on 1 DB-25) 8 balanced AES/EBU pair (on 1 DB-25) 4 AES pair (on 4 BNCs) 1 Remote (on DB-9) (reserved for future use) 3 RS-232 (on DB-9) (AMP2 models only) 2 RS-232 (on DB-9) (AMP1 models only) 2 HD/SD-SDI (on 2 BNCs) (MDA models only)
Outputs	1 HD/SD-SDI re-clocked (on BNC) (MDA models only) 8 balanced AES loop out (on 1 DB-25) 1 CVBS from SDI (MDA models + Video option only) 8 unbalanced AES out from SDI (on 1 HD-15) (MDA models only) or Option: 8 balanced AES out from SDI (on 1 DB-25) (MDA models only) 8 balanced metered analog out (on 1 DB-25)
Level meters	8 53-segment
Level meter scale	0 to -66 dB
Level meter threshold	0, +4, +6 or +8 dBv, switch selectable
Level meter dynamics	simultaneous VU and PPM
Midscale resolution	1 dB
Peak acoustic output at 2 feet	104 dB SPL
Distortion	Electrical: <0.15% at any level below limit threshold Acoustic: 6% or less worst case frequencies above 140 Hz including cabinet resonance, typically <1.5%
Magnetic shielding	<0.8 gauss any adjacent surface

Block Diagram

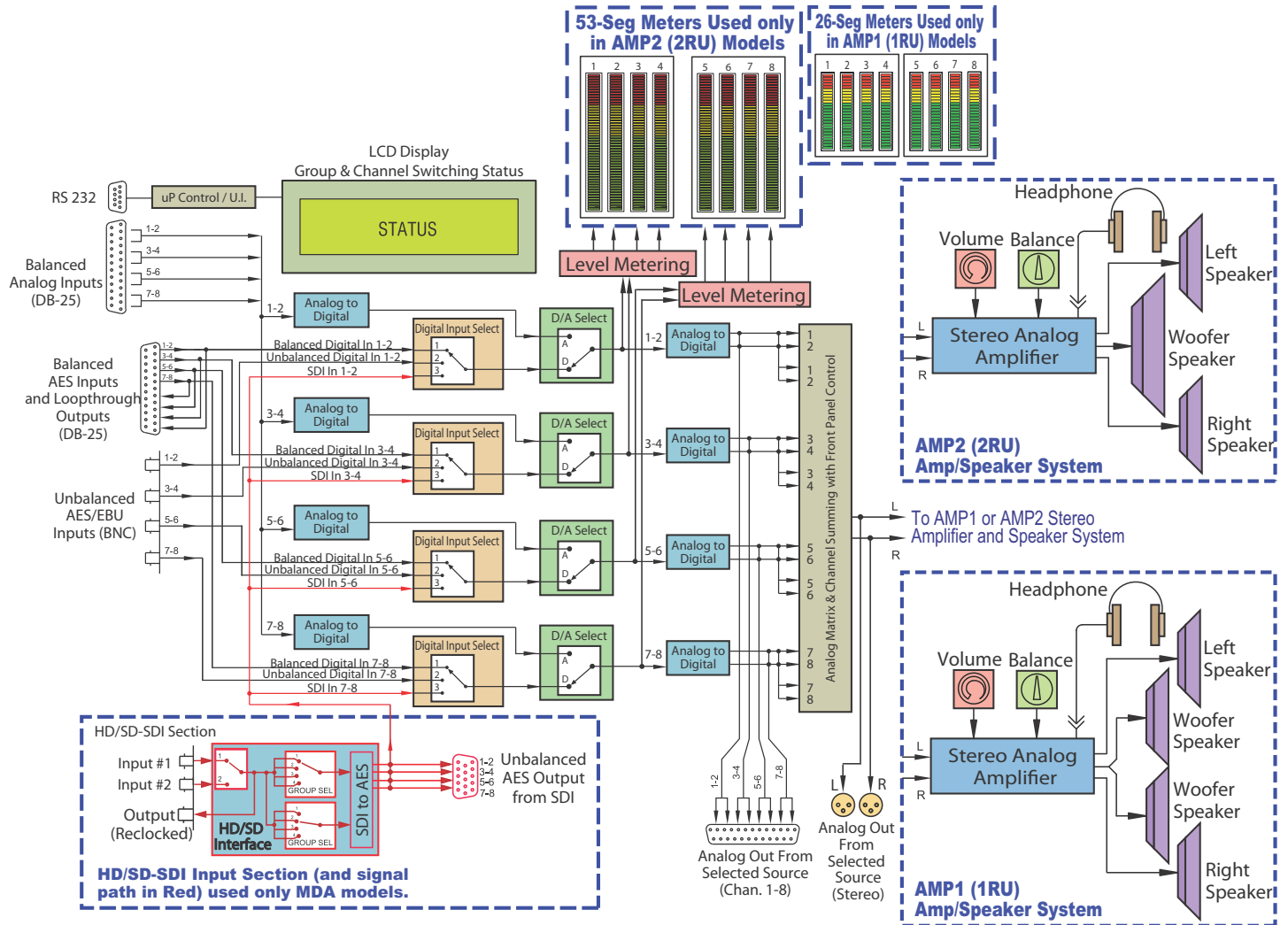

Contact

Wohler Technologies, Inc.
 31055 Huntwood Avenue
 Hayward, CA 94544 USA
 +1 888 5 WOHLER (Toll Free)
 +1 510 870-0810
 +1 510 870-0811 (fax)

Wohler Europe
 +33 970 440 253
 +33 1 77 72 59 99 (fax)
 sales@wohler.com
 www.wohler.com

Wohler Asia
 1704 Lucky Commercial Center
 103 Des Voeux Road West
 Sheung Wan, Hong Kong
 +852 2851 8325
 +852 2850 8182 (fax)