

AMP1A-30



AMP1A-106



AMP1A-Plus



AMP1A-LP10S



Description

The AMP1A Series monitors provide self-powered, full fidelity stereo audio monitoring of 2 analog channels (1 stereo channel) in the smallest rack space possible. These units contain four high performance transducers driven by three power amplifiers: one amplifier/driver combination handles midrange and high frequency information in stereo, while the second handles summed low frequency information below the 500 Hz crossover point.

The unique design provides optimally focused sound for operators in an ultra near field (1 to 3 ft.) working environment and offers performance comparable to

that of many separate monitor pairs, yet does so without the installation hassles, awkward speaker placements and “added-on” look. This provides for a higher SPL for the operator while reducing overall ambient sound and adjacent bay crosstalk.

Extended HF response reveals potential problems with audio whine or hiss. Electronic rather than acoustic cancellation of bass frequencies provides positive audible detection of out-of-phase (reversed polarity) audio feeds. A headphone jack is provided on the front panel; usage automatically mutes the speakers.

Order Part Numbers

AMP1A-30:	8100-0070 (horizontal, 30-segment meters)
AMP1A-106:	8100-0060 (horizontal, 106-segment meters)
AMP1A-Plus	8100-0320 (no level meters)
AMP1A-LP10S	8100-0130 (vertical, 10-segment meters)

The AMP1A Series monitors are ideally suited for use in VTR bays, mobile production vehicles, teleconferencing installations, multimedia systems,

satellite link and cable TV facilities, and on air radio studios.

Features

Full fidelity audio monitoring in only 1RU

Headphone jack, mutes speakers

Premium quality drivers and power amplifiers

Two balanced analog Inputs with loop-through (1 stereo)

Benefits

Thorough magnetic shielding allows placement next to video monitors.

Focused sound reduces adjacent bay crosstalk.

Extended Frequency Response and Low Distortion provide excellent reproduction.

Quick and simple installation saves time.

1RU size is perfect for space-constrained environments.

Audible indication of phase/polarity provides instant information.

Rear Panels

AMP1A-30 and AMP1A-106

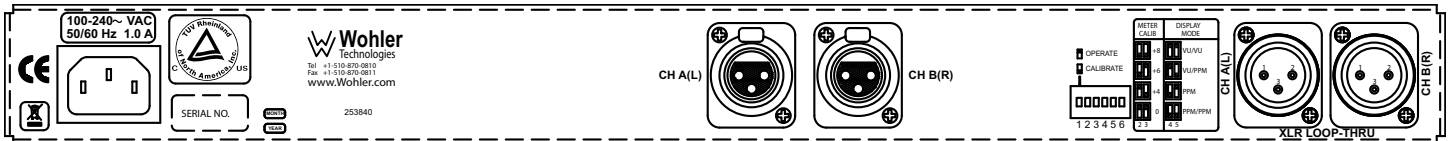

AMP1A-Plus

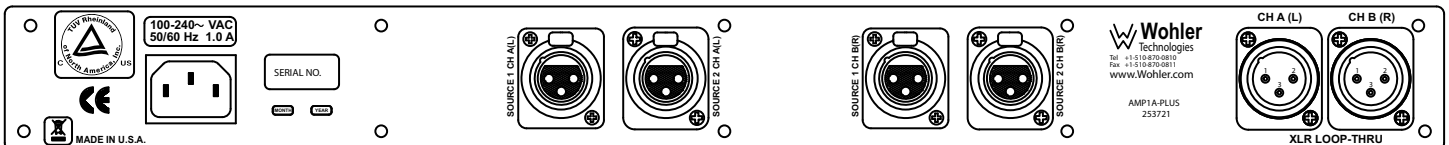

AMP1A-LP10S

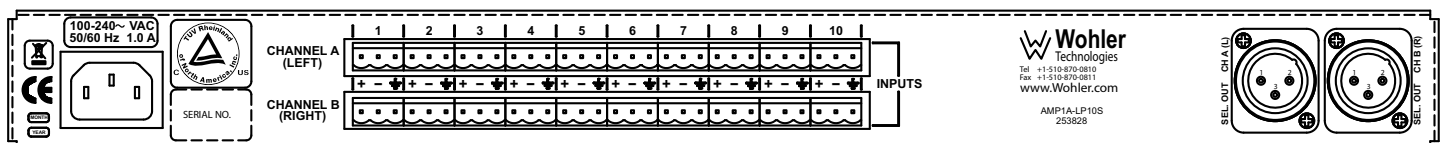

Physical Specifications

Specification	AMP1A-30	AMP1A-106	AMP1A-Plus	AMP1A-LP10S
Dimensions (H x W x D)	1.75" H x 19" W x 12" D (44.5 mm H x 483 mm W x 298 mm D)			
Shipping weight	14 lbs (6.4 kg)	14 lbs (6.4 kg)	10 lbs (4.5 kg)	14 lbs (6.4 kg)
Space requirements	1RU in a standard 19" rack			
Supplied accessories	AC power cord			
Power requirements	Power to the unit is 24V DC, 3.0 A. The external power supply then connects to mains power (100 to 240 VAC ± 10%, 50/60Hz).			
Power consumption	35 W			

Inputs and Outputs

Connectors	AMP1A-30	AMP1A-106	AMP1A-Plus	AMP1A-LP10S
Inputs	2 balanced analog audio on XLR (left & right)		4 balanced analog on XLR (left and right)	20 balanced analog audio on 2 banks of 10 Phoenix (left & right)
Outputs	2 analog audio on XLR (left & right)			

Technical Specifications

Input impedance	> 40k Ω balanced
Input level for maximum output (volume full on)	0 dB balanced
Input overload	+26 dBv balanced
Peak acoustic output (at 2 ft.)	98 dB SPL
Response, 6th octave	80 Hz to 16 kHz \pm 7 dB (-10 dB @ 50 Hz to 22 kHz)
Power output	
RMS each side	10 W transient / 5 W continuous
RMS base	20 W transient / 10 W continuous
Distortion, electrical	< 0.15% at any level below limit threshold
Distortion, acoustic	8% or less at worst case frequencies above 180 kHz including cabinet resonance; typically <2%
Hum and noise	Better than -68 dB below full output
Magnetic shielding	<1 Gauss any adjacent surface

Block Diagrams

AMP1A-30

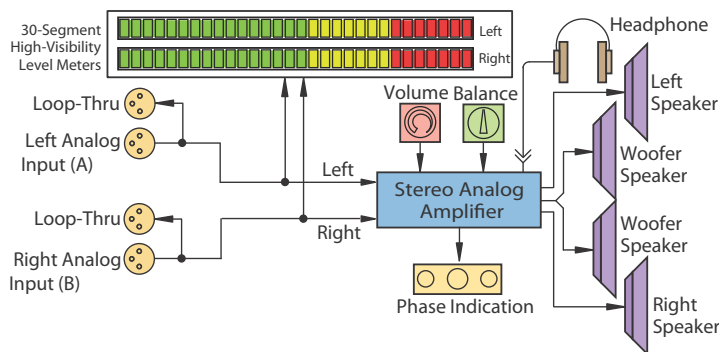

AMP1A-106

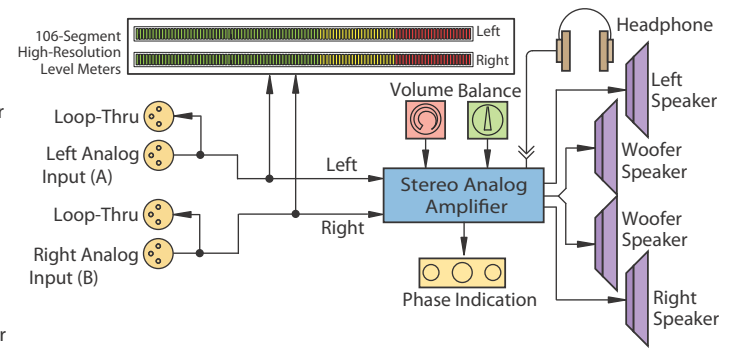

AMP1A-Plus

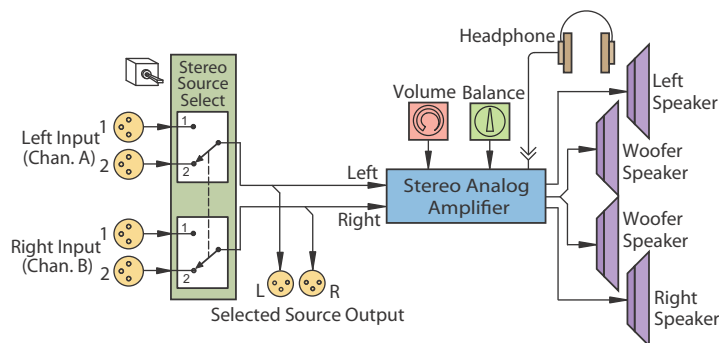

AMP1A-LP10S

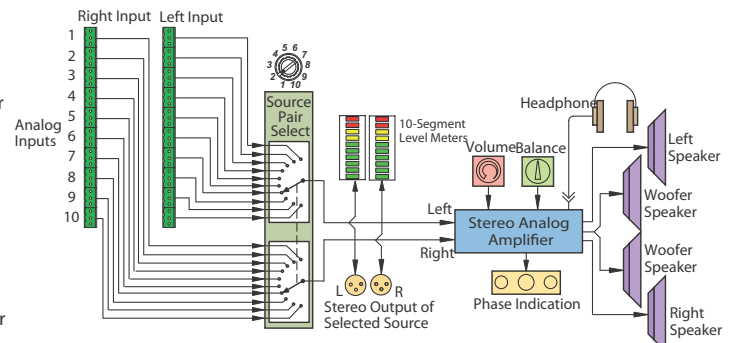

Contact

Wohler Technologies, Inc.
 31055 Huntwood Avenue
 Hayward, CA 94544 USA
 +1 888 5 WOHLER (Toll Free)
 +1 510 870-0810
 +1 510 870-0811 (fax)

Wohler Europe
 +33 970 440 253
 +33 1 77 72 59 99 (fax)
 sales@wohler.com
 www.wohler.com

Wohler Asia
 1704 Lucky Commercial Center
 103 Des Voeux Road West
 Sheung Wan, Hong Kong
 +852 2851 8325
 +852 2850 8182 (fax)