

---

## AMPx-D8 Series

- AMP1-D8DA
- AMP2-D8DA
- AMP1-D8MDA-3G
- AMP2-D8MDA-3G

2RU, Dolby, Multi-Format, Analog/  
Digital Audio Monitors

User Guide

**Part Number 821077, Revision C**

---



VIDEO

31055 Huntwood Avenue  
Hayward, California  
94544 USA



AUDIO

1 800 5 WOHLER  
+1 (510) 870-0810  
Fax +1 (510) 870-0811



CAPTIONING

[www.wohler.com](http://www.wohler.com)  
[info@wohler.com](mailto:info@wohler.com)



LOUDNESS

© 2013 Wohler Technologies, Inc. All rights reserved.

This publication is protected by federal copyright law. No part of this publication may be copied or distributed, stored in a retrieval system, or translated into any human or computer language in any form or by any means electronic, mechanical, manual, magnetic, or otherwise, or disclosed to third parties without the express written permission of Wohler Technologies.

## Reproduction

Licensed users and authorized distributors of Wohler Technologies, Inc. products may copy this document for use with Wohler Technologies, Inc. products provided that the copyright notice above is included in all reproductions.

## Customer Support

Wohler Technologies, Inc.  
31055 Huntwood Avenue  
Hayward, CA 94544  
www.wohler.com

Phone: 510-870-0810  
FAX: 510-870-0811  
US Toll Free: 1-888-596-4537  
(1-888-5-WOHLER)  
Web: www.wohler.com  
Sales: sales@wohler.com  
Support: support@wohler.com

## Disclaimers

Even though Wohler Technologies, Inc. has tested its equipment and software, and reviewed the documentation, Wohler Technologies, Inc. makes no warranty or representation, either express or implied, with respect to software, documentation, their quality, performance, merchantability, or fitness for a particular purpose.

Wohler Technologies, Inc. reserves the right to change or improve our products at any time and without notice.

In no event will Wohler Technologies, Inc. be liable for direct, indirect, special, incidental, or consequential damages resulting from any defect in the hardware, software, or its documentation, even if advised of the possibility of such damages.

Some states do not allow the exclusion or limitation for incidental or consequential damages, so the above exclusion or limitation may not apply to you.

## Printing

This document is intended to be printed on a duplex printer, such that the copy appears on both sides of each page. This ensures that all new chapters start on a right-facing page.

This document looks best when printed on a color printer since some images may be indistinct when printed on a black and white printer.

## Other Technologies and Products

Dolby, Dolby Digital (AC-3), Dolby D and the Dolby logo are registered trademark of Dolby Laboratories, Inc., a licensor of technology used in this product. For more information concerning Dolby Digital and Dolby Digital (AC-3), please contact Dolby Laboratories directly at Phone: 415-558-0200, info@dolby.com, or Dolby Laboratories, Inc., 100 Potrero Avenue, San Francisco, CA 94103

Microsoft Windows, and Internet Explorer are registered trademarks of Microsoft Corporation.

The Tascam trademark is owned by Teac, Inc.

## Last Update

May 15, 2013

# Table of Contents

---

<b>Chapter 1. Safety and Installation</b> . . . . .	<b>1</b>
Introduction . . . . .	1
Overview . . . . .	1
Topics . . . . .	1
Unpacking . . . . .	2
Safety . . . . .	2
Important Safety Instructions . . . . .	2
Safety Symbols . . . . .	3
FCC Compliance . . . . .	3
Installation Recommendations . . . . .	4
Mounting . . . . .	4
Heat Dissipation . . . . .	4
Sympathetic Vibration . . . . .	5
Mechanical Bracing . . . . .	5
Audio Connections and Cable Recommendations . . . . .	5
Electrical Interference . . . . .	5
Power . . . . .	6
Installation . . . . .	6
Initial Setup . . . . .	6
Power Up . . . . .	6
<b>Chapter 2. System Overview</b> . . . . .	<b>7</b>
Introduction . . . . .	7
Overview . . . . .	7
Topics . . . . .	7
Front Panel Controls . . . . .	8
Features and Simple Controls . . . . .	8
LCD Screen . . . . .	10

User Interface .....	12
Multi-Mode Color Codes .....	12
Menu Navigation .....	13
Rear Panel Connectors .....	13
Input Connectors .....	15
Output Connectors .....	16
Programming and Remote Access Connectors .....	19
RS-232 Connectors .....	19
Remote Connector .....	20
Rotary Switches .....	20
Monitoring Inputs .....	22
Monitoring an Analog Input .....	22
Monitoring an AES Input .....	22
Monitoring an SDI Input .....	23
Monitoring a Dolby Input .....	23
Monitoring Dolby in SDI .....	24
Channel Selection and Mixing .....	24

## **Chapter 3. Audio Configuration . . . . . 27**

Introduction.....	27
Overview .....	27
Topics .....	27
Analog Output Preference .....	28
Monitoring and Mixing Modes .....	29
Arbitrary Mixing .....	29
Single .....	30
Pairs .....	30
Downmix .....	31
Muting the Speakers .....	33
Phase Correlation .....	34

SDI Inputs .....	35
Selecting SDI Groups and Subgroups .....	35
Dolby Decode Mode Disabled .....	35
Dolby Decode Mode Enabled .....	36
Configuring for SDI Delay .....	37
Selecting the Input Signal .....	38
Setting the Monitor's Startup Configuration.....	39
Terminating/Unterminating Inputs .....	40

## **Chapter 4. Presets. .... 43**

Introduction .....	43
Overview.....	43
Topics .....	43
What are Presets? .....	44
Methods of Accessing the Presets .....	44
Setup Menu .....	44
Preset Mode.....	44
Enabling/Disabling Preset Mode .....	45
Recalling a Preset .....	45
Speaker Assign/Preset Buttons (Presets 1 through 4 Only) .....	45
Saving a Preset .....	46
Recalling a Preset .....	46
Overwriting a Preset .....	46

## **Chapter 5. Dolby . .... 49**

Introduction .....	49
Overview.....	49
Topics .....	49
Dolby Input Source Selection .....	50
Dolby Decoding.....	50
PCM .....	51
Dolby Metadata.....	52

**Chapter 6. Setup Menu . . . . . 55**

- Introduction.....55
  - Overview .....55
  - Topics .....55
- Accessing Setup Mode.....56
- Analog Output Preference Mode.....58
- Recalling a Preset .....58
- Saving a Preset .....59
  - Creating a New Preset .....60
  - Overwriting an Existing Preset .....61
- Presets Mode.....63
- Erasing a Preset .....64
- SDI Delay.....65
- Startup .....65
- Surround Gain .....66
- Bitstream Detection .....66
- Phase Bits .....67

**Chapter 7. Features and Specifications . . . . . 69**

- Introduction.....69
  - Overview .....69
  - Topics .....69
- Features.....70
  - Common Features.....70
  - Model Distinctions.....71
- Specifications.....71
- Technical Functional Overview .....73

# CHAPTER 1

# Safety and Installation

---

## Introduction

### Overview

---

This chapter describes the procedures for installation, including installation recommendations for optimal performance, and safety guidelines.

### Topics

---

Topics	Page
Introduction	1
Unpacking	2
Safety	2
Compliance	3
Installation Recommendations	4
Installation	7

# Unpacking

Unpack the AMPx-D8 Series monitor and inspect for any apparent physical damage that may have occurred in transit. If the unit has been damaged, contact Wohler customer support for assistance. (Wohler's contact information is on page ii of this document.)

In addition to the monitor, the package should contain:

- A CDROM containing the product's user guide,
- A power cord, and
- A warranty card

**Note:** We recommend you retain the shipping carton for future use.

## Safety

### Important Safety Instructions

---

1. Read, keep, and follow all of these instructions; heed all warnings.
2. Do not use this equipment near water, rain or moisture.
3. Use only a dry cloth to clean the equipment.
4. Do not block any ventilation openings. Install only in accordance with the instructions in the section entitled [Installation Recommendations on page 4](#).
5. Do not install near any heat source such as a radiator, heat register, amplifier, or stove.
6. Do not attempt to plug the unit into a two-blade outlet (with only two prongs of equal width).

**IMPORTANT:** By design, these monitors will only plug into a three-prong outlet for your safety. If the plug does not fit into your outlet, contact an electrician to replace the obsolete outlet.



7. Protect the power cord from being walked on or pinched, particularly at plug's source on the equipment and at the socket.
8. Use only the attachments/accessories specified by the manufacturer.
9. Unplug the equipment during lightning storms or when unused for long periods of time.
10. Use of a cart is neither recommended nor approved by Wohler.
11. Refer all servicing to qualified service personnel. Servicing will be required under all of the following conditions:
  - The equipment has been damaged in any way, such as when the power-supply cord or plug is damaged.
  - Objects have fallen onto the equipment; or the equipment has been exposed to rain or moisture, or liquid has been spilled onto the equipment.
  - The equipment does not operate normally.
  - The equipment has been dropped.

## Safety Symbols

---

**WARNING:**

The symbol to the left is a warning to be careful of electric shock. Do not open the top cover with the power cord attached.



## Compliance

### FCC

---

This equipment has been tested and found to comply with the limits for a Class A digital device, pursuant to part 15 of the FCC Rules. These limits are designed to provide reasonable protection against harmful interference when the equipment is operated in a commercial environment. This equipment generates, uses, and can radiate radio

frequency energy and, if not installed and used in accordance with the instruction manual, may cause harmful interference to radio communications. Operation of this equipment in a residential area is likely to cause harmful interference in which case the user will be required to correct the interference at his own expense.

## IC-ECES-003

---

This Class A digital apparatus complies with Canadian ICES-003.

Cet appareil numérique de la classe A est conforme à la norme NMB-003 du Canada.

# Installation Recommendations

## Mounting

---

The unit is designed to install into a standard 19" rack mounted at ear level for best high frequency response and visual observation of the monitor screen. Please adhere to the following clearances:

Clearance	Surface
24"	Front
3"	Rear
2"	Sides
1.75"	Top and Bottom (if either radiates heat)
0"	Top and Bottom (if no heat)

## Heat Dissipation

---

The ambient temperature inside the mounting enclosure should not exceed 40° Celsius (104° Fahrenheit). Adjacent devices can be rack mounted (or stacked) in proximity to the unit if this temperature is not exceeded. Otherwise, allow a 1RU (1.75" / 44.45mm) space above and below the unit for air circulation.

**Important:** To reduce noise, the monitor does not have any fans. As a result, the heat generated by the power amplifiers, power supplies, and other components is vented by slots in the side of the unit. Therefore, as a safety precaution, you must allow proper ventilation on both sides of the unit.

## Sympathetic Vibration

---

Sympathetic vibration from other equipment (cables, etc.) in the rack may be serious enough to interfere with the unit's sound quality. The use of thin card stock and/or felt or foam weather-stripping type materials between adjacent vibrating surfaces, or tying up loose cables, etc., may be required to stop vibrations external to the unit.

## Mechanical Bracing

---

Even though the 2U models are fairly heavy, the chassis is securely attached to the front panel. In addition, the chassis has mounting tabs through which you attach it to the rack rail. This feature will reduce or eliminate rear bracing requirements in many mobile/portable applications. The weight of internal components is distributed fairly evenly around the unit.

## Audio Connections and Cable Recommendations

---

We recommend that you limit the length of the cables that you use for feeding HD-SDI signals sources to the HD-SDI inputs of the AMPx-D8 Series units and that you use a Belden 1694A cable (or equivalent).

**Note:** The connections of all DB-25 connectors are compatible with Tascam DB-25 to XLR cable assemblies. Consult the factory for availability. All rear panel connectors are female except for the XLR connectors.

**Table 1-1 Cable Length Limit Recommendations**

Signal Type	Maximum Length	
	Meters	Feet
SD	300	984
HD	150	492
3G	22	75

## Electrical Interference

---

Be careful to apply proper input termination settings and avoid mismatched cable types and other similar causes of undesired reflections in digital signal systems. If severe enough, such reflections can result in corruption of the digital data stream. As with any audio

equipment, maximum immunity from electrical interference requires the use of shielded cable; however, satisfactory results can sometimes be obtained without it. The internal circuitry ground is connected to the chassis.

## Power

---

The unit comes with a standard 24VDC/3.0 A internal power supply and connects an A/C mains power source (65W, 100 to 240 VAC, 50/60Hz) through the IEC connector provided on the rear panel of the unit.

When the mains plug or appliance coupler is used as the disconnect device, the disconnect device should remain operable.

# Installation

## Initial Setup

---

1. Carefully install the monitor into a standard 19"-rack.
2. Connect all signal cables to and from associated equipment.
3. Connect the power cord from the monitor to A/C mains.

## Power Up

---

The AMPx-D8 Series monitors are factory-configured so that all settings are non-volatile. When power to the unit is cycled (off/on), the unit will restore itself so that each setting such as channel selection(s), input type, and so on, are automatically restored to the unit's previous factory setting. However, you can custom configure the monitor to automatically restore your configuration settings on power up. Refer to [Setup Menu on page 55](#) for details.

## Chapter 1 Safety and Installation Installation

# CHAPTER 2

# System Overview

---

## Introduction

## Overview

---

This chapter describes how to install the AMPx-D8 Series monitor into a standard 19"-rack and how to connect the audio cables.

## Topics

---

Topics	Page
Introduction	7
Front Panel Controls	8
Rear Panel Connectors	13
Monitoring Inputs	22
Channel Selection and Mixing	24

# Front Panel Controls

## Features and Simple Controls

---

Refer to the images in and [Figure 2-2](#) on the next page.

**Note:** On the AMP1s, the top LED segment of each bar graph serves as the speaker assign LED for the respective channel.

- **Speakers:** The AMP2s features two mid-range speakers (left and right) and one woofer speaker. The AMP1s have two woofers. All models of the AMPx-X8 Series contain high performance transducers driven by three power amplifiers. Two amplifier/driver combinations handle midrange and high frequency information in the left and right (stereo) speaker channels, while the third channel reproduces and sums the left and right channel information below the crossover point in the woofer (bass) speaker. Note that the woofer channel is not a dedicated LFE (sub-woofer) or center channel.
- **Level Meters (1 through 8):** Source channels 1 through 8 are displayed through eight audio level meters (four on the left side; four on the right side). These level meters, high-resolution LED bar graph displays and feature a dynamic range of 66 dB with PPM dot over VU bar ballistic characteristics.
- **Headphones (1/4" Jack):** Select the headphone audio sources as you would for the internal speakers. When you plug in headphones the speakers will mute.
- **Volume (Rotary Knob):** This control adjusts the loudness of the audio reproduced by the internal speaker channels or connected headphones.
- **Balance (Rotary Knob):** This control adjusts the volume balance between the left and right speaker channels. Note that this control attenuates the signal from the source, so that the left and right bass frequencies (summed together and reproduced in the woofer channel) will respond to balance adjustments in tandem with the left and right speaker channels.



**Figure 2-1 The AMP1-D8 Series Front Panel**

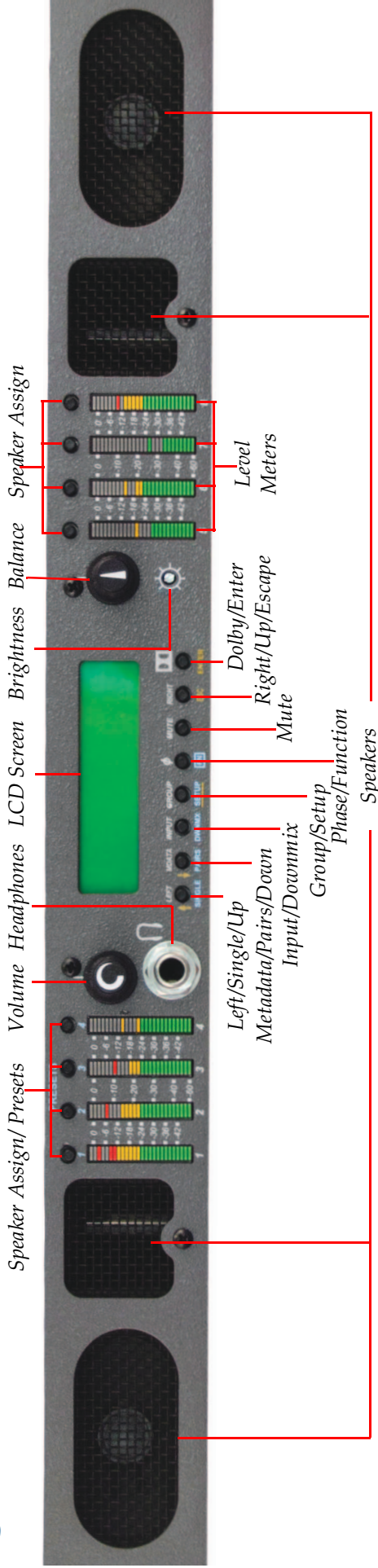

**Figure 2-2 The AMP2-D8 Series Front Panel**

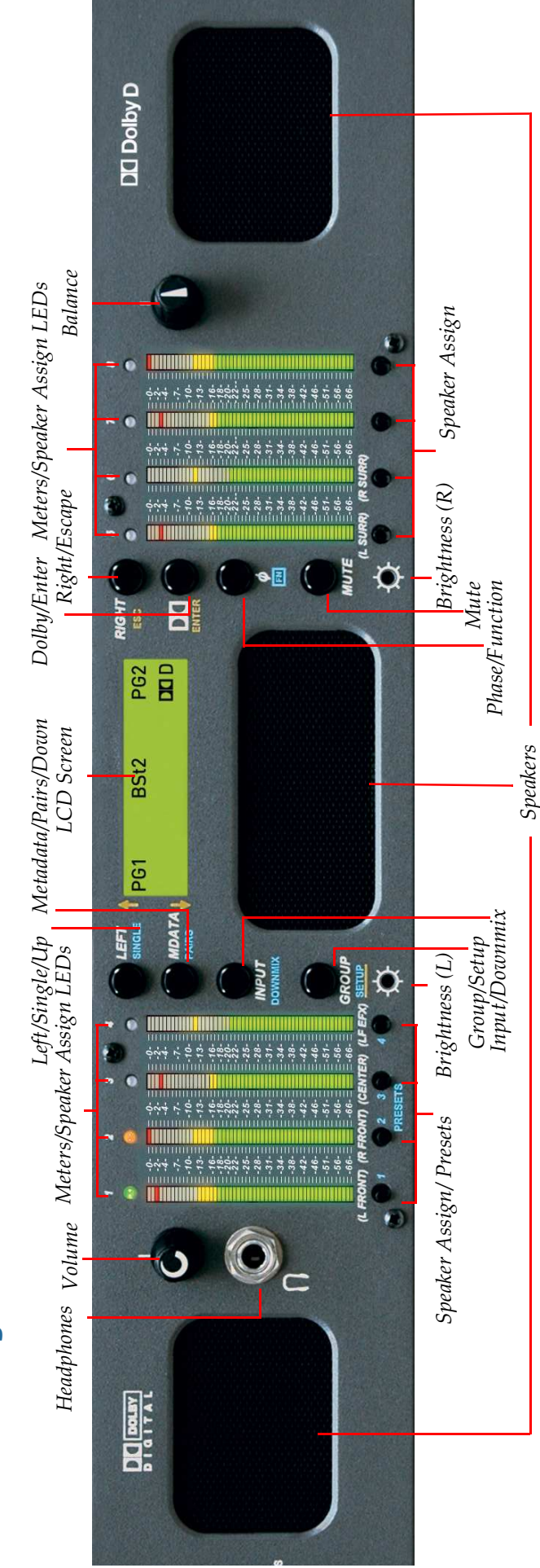

- **Level Meter Brightness** (Potentiometers, Left and Right): Use a small slot screwdriver to adjust the brightness of the bar graph meters using these two recessed trim pot controls. The left control adjusts the brightness of the left four LED bar graphs and the right control adjusts the brightness of the right four bar graphs. Clockwise rotation increases the brightness.  
**Note:** The AMP1s only have one brightness control.
- **Speaker Assign LEDs** (1 through 8, Left and Right): These LEDs indicate the speaker mix of selected channels. The speaker assign LEDs are located above each of the 53-segment bar graphs.  
**Note:** In the AMP1s, the speaker assign LEDs are the top segment of the meters.
- **Speaker Assign/Presets Buttons** (Speaker Assign, 1 through 8; Preset Buttons, 1 through 4): Pressing any of these buttons selects the channels to be summed into either or both speaker channels, or to create and recall presets when used in conjunction with the **FN** button. Refer to [Chapter 4 on page 43](#) for more information about presets.

## LCD Screen

---

The LCD screen displays various parameters and settings, and is also used to configure/program the monitor. The features of the LCD screen (shown in [Figure 2–3](#) through [Figure 2–6](#) on the next page) include:

- **Mix Status:** Displayed on the top right and top left corners of the LCD screen, the **Mix Status** indicates how the current input signal is mixed to the internal speakers.
- **Source Status:** Displayed in the top center of the LCD screen, the **Source Status** indicates the current signal type and current input currently audible in the internal speakers. If a preset has been recalled, this area displays the name of the preset until a monitoring or input change is made.
- **SDI Groups/Dolby Signal Type:** Displayed in the bottom left and bottom right corners of the LCD screen, these groups indicate the SDI channels that are currently mixed to the internal speakers. In the case when a Dolby signal is mixed to the internal speakers, the bottom left corner will be blank and the bottom right corner will display the Dolby logo, **PCM**, **DAT**, or **---** (no input signal).

- **Input Lock Status (Digital Inputs Only):** Displayed in the center of bottom line, the **Input Lock Status** shows the lock status of the selected digital input(s). If any input channel pairs are not locked, then they will display as short dashes. Each dash (-) indicates a position for displaying the channel pairs available for monitoring from left to right: 1/2, 3/4, 5/6 and 7/8. The unit updates the **Input Lock Status** whenever it detects a signal change. See [Figure 2-3](#) below through [Figure 2-6](#) on page 12 for additional examples.

**Figure 2-3 Status Display Example: Standard Input Source - SD-SDI Input 2**

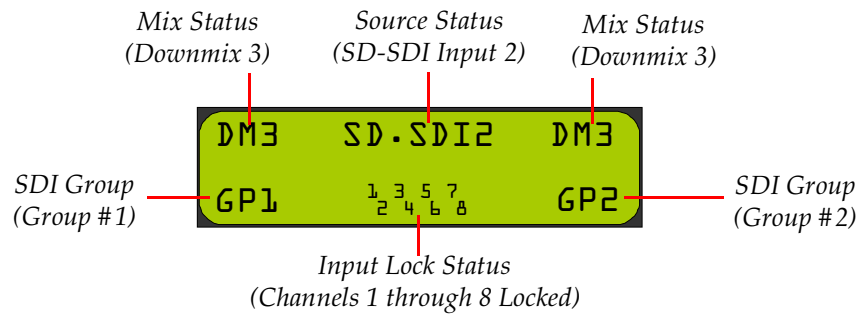

**Figure 2-4 Status Display Example: Standard Input Source - HD-SDI Input 1**

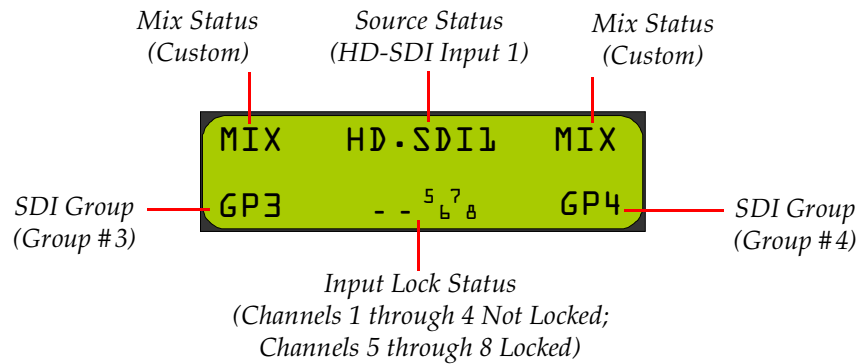

**Figure 2-5 Status Display Example: Dolby Input Source - Bitstream 1**

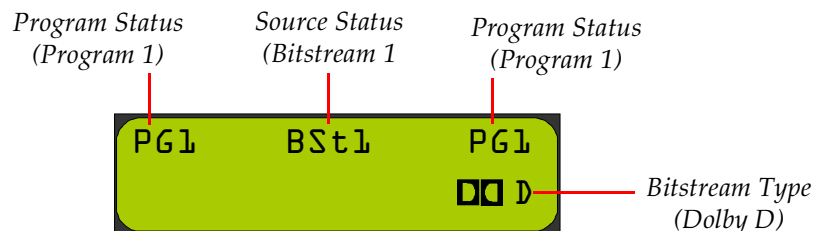

**Figure 2–6 Status Display Example: Dolby Input Source - Bitstream 2**

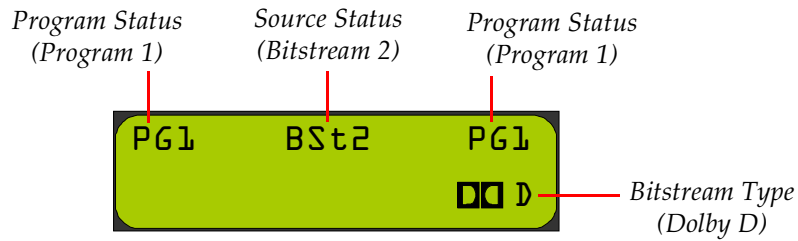

## User Interface

### Multi-Mode Color Codes

Most of the user interface buttons are multi-functional. They affect the unit differently depending on whether they are used alone or in combination with another button. The monitor’s front panels have color-coded legends to help identify the different functions of each button:

- **White** indicates normal operation.

**Table 2–1 White Control Functionality**

Button	Functionality
<b>Left</b>	Displays the next channel to the left
<b>Right</b>	Displays the next channel to the right
<b>MData</b>	Selects Dolby metadata for display
<b>□□</b>	Toggles between using the Dolby Decode mode or not
<b>Input</b>	Selects inputs for monitoring
$\phi$	Displays the phase correlation for the currently-monitored input pairs
<b>Group</b>	Selects the channel groups and subgroups for an SDI signal
<b>Mute</b>	Mutes the audio currently playing in the front panel speakers

- **Blue** indicates functions that are controlled by the **Fn** button.

**Table 2–2 Blue Control Functionality**

Button	Functionality
<b>Fn + Single</b>	Selects single channel monitoring mode: one channel per speaker, selected independently
<b>Fn + Pairs</b>	Selects pair monitoring mode: one channel per speaker, selected pair by pair
<b>Fn + Downmix</b>	Selects downmix mode: one of several available downmixes
<b>Fn + Setup</b>	Displays the Setup menu

- **Yellow** indicates the button functions for the Setup menu. Refer to [Chapter 6 on page 55](#) for more details about using the Setup menu for system configuration.

**Table 2–3 Yellow Control Functionality**

Button	Functionality
↑	Displays the previous menu item
↓	Displays the next menu item
<b>Esc</b>	Returns to the previous menu and cancels changes
<b>Enter</b>	Returns to the previous menu and saves changes

## Menu Navigation

When making changes to the Setup menu, you will generally press the **Enter** button to select menu options and settings, and press the **Esc** (Escape) button to back out of the menu, setting, or display to return to normal operation.

# Rear Panel Connectors

Descriptions of each of the rear panel connectors follow [Figure 2–8 on page 14](#).



**Figure 2-7 The AMP1-D8MDA-3G Rear Panel**

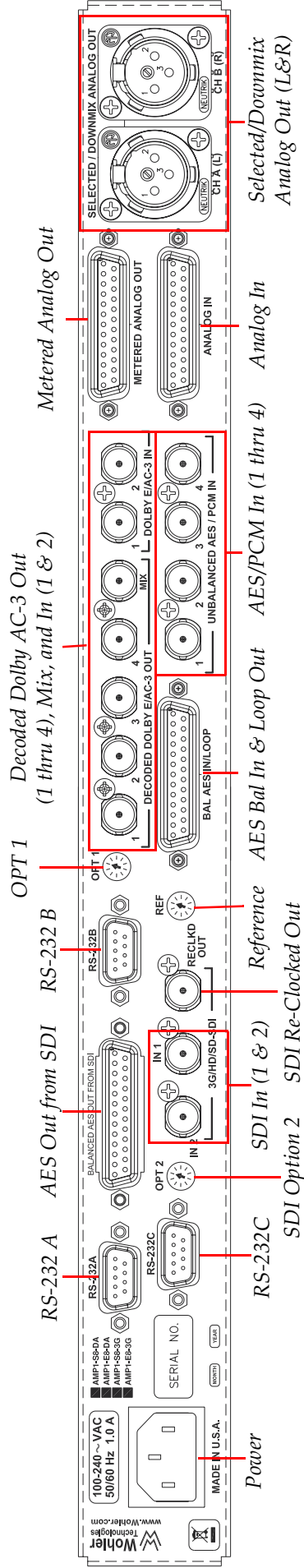

**Figure 2-8 The AMP2-D8MDA-3G Rear Panel**

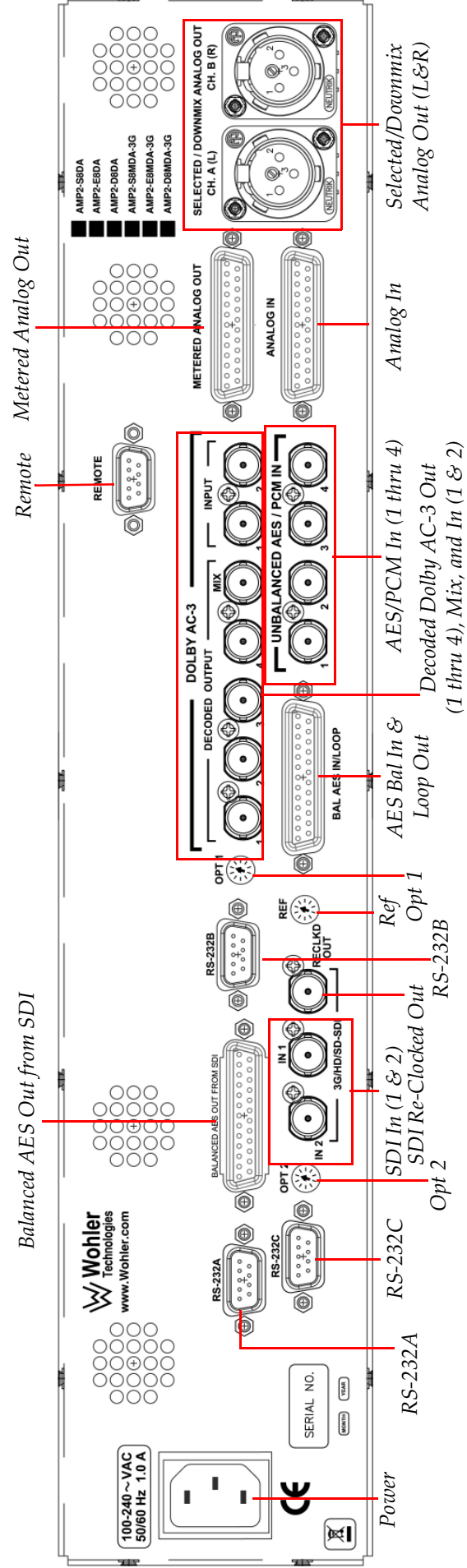

Note that the DA models do not have SDI connectors.

- **Analog In (DB-25-F):** This connector accepts balanced, low impedance, line level analog signals. See [Figure 2-9](#) below for pin-out information.

**Figure 2-9 Analog Input Connector Pin-Out**

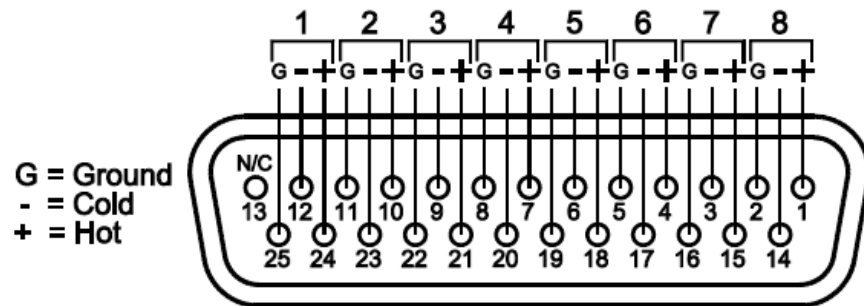

## Input Connectors

- **Power:** Attach a standard IEC-320 power cord between this connector and AC mains power.
- **AES/PCM In (1 through 4, BNC-F):** These connectors accept unbalanced (75  $\Omega$ ) PCM (AES/EBU) formatted signals. These inputs appear as **AES1** in the LCD screen.

If you are not connecting downstream equipment, then you should terminate the selected input connector. Otherwise, unterminate them.

- **AES/PCM In (and Loop Out) (DB-25-F):** This connector accepts balanced (110  $\Omega$ ) AES signals. Inputs are internally connected to the loop-through outputs. These inputs are referred to as **AES2** in the LCD screen. If you are connecting downstream equipment to the AES loop-through outputs of this connector, then you should unterminate this connector. If you are not connecting downstream equipment, then you should terminate them. Refer to [Terminating/Unterminating Inputs](#) on page 40 for details.

**Note:** The pin-out for this connector is compatible with Tascam DB-25 to XLR cable assemblies. Contact your Wohler sales representative for availability. (Wohler's contact information is on page ii of this document.)

**Figure 2-10 AES/PCM Input and Loop-Through DB-25 Pin-Out**

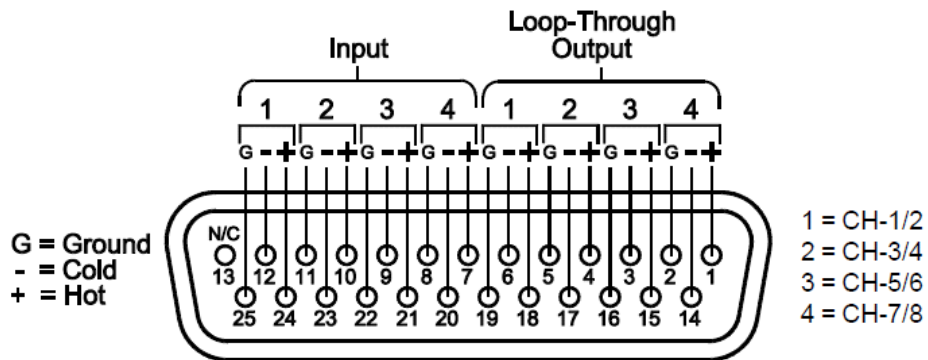

- **Dolby AC-3 In** (1 and 2, BNC-F): These connectors accept Dolby Digital (AC-3), or PCM (AES/EBU) formatted signals. These inputs are selected when the LCD screen shows either **BSt1** or **BSt2**. Select either **BSt1** or **BSt2** for decoding and monitoring by using the **Input** button when the unit is in Dolby Decode Mode.

If you are connecting downstream equipment to the AES loop-through outputs of this connector, then you should unterminate this connector. If you are not connecting downstream equipment, then you should terminate the selected input connector. Refer to [Terminating/Unterminating Inputs on page 40](#) for details.

- **3G/HD/SD-SDI In** (1 and 2, BNC-F): These inputs accept SDI video signals for the 3G models.

**Note:** The DA model does not feature SDI capability.

If Dolby D (AC-3) audio signals are encoded within an SDI bitstream selected in Dolby Decode Mode, they will be de-embedded and de-coded for monitoring through the unit and for output through the Decoded Dolby AC-3 Out connectors. PCM signals embedded within the SDI bitstream are also de-embedded for monitoring through the unit. See [Chapter 5: Dolby on page 49](#) for details.

## Output Connectors

- **Metered Analog** (DB-25): This connector outputs the analog signal that is displayed on the front panel level meters. The pin-out information for this DB-25 is identical to that of the **Analog Input** connector. See [Figure 2-7 on page 14](#).



**Note:** The Analog Output Preference (**AOutputPref**) entry within the Setup Menu determines how this connector outputs the speaker Assign when a DM1, DM2, or DM3 downmix selection is enabled. The default setting is **Downmix**, which outputs the metered signal with individual channel scaling (gain settings) intact as determined by the selected downmix (DM1, DM2, or DM3). If **Discrete** is selected, then all metered channels are output from these connectors at unity gain. See [Analog Output Preference Mode on page 58](#) for information on how to set this parameter.

- **3G/HD/SD-SDI Re-Clocked Out (BNC):** This connector outputs a re-clocked copy of the SDI signal fed to the SDI input connector selected for monitoring. When an SDI input is not selected for monitoring in the unit, **SDI In 2** will be reclocked and connected to this output by default.
- **AES Unbalanced Out from SDI (HD-15):** This connector outputs de-embedded audio. The last SDI input and group selection determine which audio pairs are de-embedded on these 75 Ω, unbalanced, AES outputs. No other monitoring function affects these outputs. Embedded Dolby signals are here as bitstreams, and are presented here as a bitstream, and are not decoded.

The pinout of this connector is the same as that for a standard VGA cable. VGA cables may be used to break out the HD-15 connectors into separate BNCs.

**Note:** The DA model does not feature SDI capability.

**Table 2–4 VGA Connector Pin-Out**

SDI Channels	Cable Color/Function
1 and 2	Red
3 and 4	Green
5 and 6	Blue
7 and 8	Grey/H-Sync.
Not Used	Black/V-Sync.

**Figure 2-11 AES Unbalanced Out from SDI HD-15 Pin-Out**

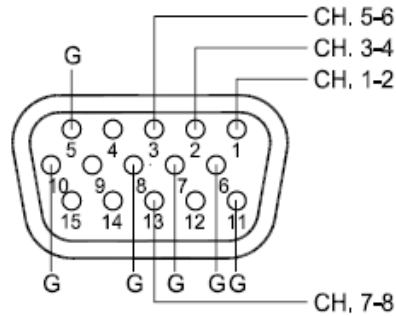

**Note:** You must specify either the balanced (DB-25) or the default unbalanced (HD-15) output connector at the time you place your order.

- (Optional) **Balanced AES Output from SDI Input (DB-25):** This connector outputs de-embedded audio. The last SDI input and group selection determine which audio pairs are de-embedded on these 110 Ω, unbalanced, AES outputs. No other monitoring function affects these outputs. Embedded Dolby signals are here as bitstreams, and are presented here as a bitstream, and are not decoded.

The pin-out for this connector is compatible with Tascam DB-25 to XLR cable assemblies. Contact your Wohler sales representative for availability. (Wohler’s contact information is on page ii of this document.).

**Figure 2-12 AES Balanced Out from SDI DB-25 Pin-Out**

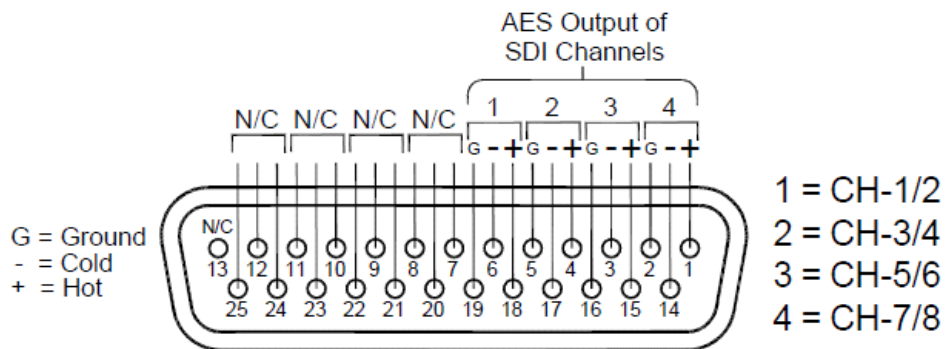

- **Selected Downmix/Analog Out (Left and Right, XLR-M):** These connectors are balanced analog outputs of the speaker assign (or

downmix) source as selected for the left and right speaker channels. See the pin-out diagram in [Figure 2–13 on page 19](#).

**Figure 2–13 XLR-M Pin-Out**

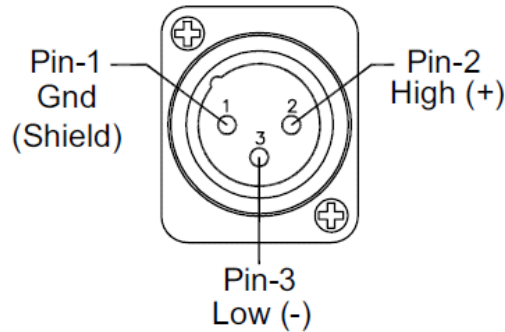

- **AES Bal In/Loop Out (DB-25):** This connector contains both inputs and looped outputs. Refer to AES/PCM In (and Loop Out), [page 15](#) for a full description.

## Programming and Remote Access Connectors

---

### RS-232 Connectors

**Figure 2–14 RS-232 Pin-Out**

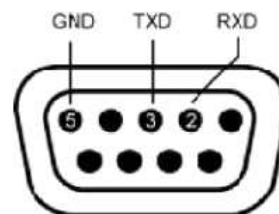

- **RS-232 A (DB-9):** This connector is used for downloading programming, setup, and diagnostic information into and out of the main board.
- **RS-232 B (DB-9):** This connector is used for downloading programming, setup, and diagnostic information into and out of the Dolby card.
- **RS-232 C (DB-9) (not available on the DA models):** This connector is used for downloading programming, setup, and diagnostic information into and out of the 3G card.

## Remote Connector

**Remote** (DB-9) (2RU models only): When equipped with the optional RC4-4 interface board and configured in software, this connector (**not** RS-232) provides limited remote control and status reporting with GPI/O signals: four inputs (Controls 1 through 4) and four outputs (Status 1 through 4) as shown in [Table 2-5](#) below.

**Table 2-5 RC4-4 Connector Interface Pin Out**

Pin	Description
1	Type Select 1, Status Output
2	Type Select 0, Status Output
3	Common, Ground
4	Type Select 0, Control Input
5	Channel Select 0, Status Output
6	Channel Select 1, Status Output
7	Channel Select 0, Control Input
8	Channel Select 1, Control Input
9	Type Select 1, Control Input

**Note:** For more complete information about the functionality of the **Remote** connector, contact your Wohler technical support representative and ask for the documents with part numbers 824016 and 824017.

## Rotary Switches

---

- **OPT 1** (10-Position Rotary Switch): This recessed 10-position rotary switch allows for standard operation and software upgrades. Refer to [Table 2-6](#) for the position values.

**Table 2-6 OPT 1 Option Settings and Descriptions**

Position	Setting Description
0 thru 7	Operational Mode (Default=1)
8 thru 9	Software Upgrade

- **OPT2** (10-Position Rotary Switch): This recessed 10-position rotary switch that is reserved for future use and should be left at the factory position of 1.

**Table 2–7 SDI Option Settings and Descriptions**

Position	Setting Description
0	Not Used - Reserved for Future Use
1	Operational Mode
2 thru 8	Not Used - Reserved for Future Use
9	Software Upgrade

- **REF** (10-Position Rotary Switch): This recessed 10-position rotary switch allows you to set the analog and digital reference levels for the unit’s level meters, as well as to select the software upgrade function. In [Table 2–8](#) below, the analog reference level (analog, left column) is the analog input level needed to activate the bar graph segment at the associated digital reference level (digital, right column) value. This is usually the location on the bar graph level meter where the color transitions from green to amber.

**Table 2–8 Reference and OPT2 Setting Values and Definitions**

Position	Reference Level Function	
	Analog (dBu)	Digital (dBFS)
0	+8	-20
1	+4	
2	0	
3	0	-18
4	+6	-9
5	+4	-18
6	Custom Settings for Alternate Scales	
7	Not Used	
8	For software Upgrades Only	
9		

---

**Example:** Choosing position 2 (0 dBu = -20 dBFS) means an analog input level of 0 dBu will light up the LED segment associated with the digital -20 dBFS value on the bar graph meter and also transition from green to amber at that segment.

---

# Monitoring Inputs

The following simple instructions will allow you to get your AMPx-D8 Series monitor up and running quickly; that is, you will be able to monitor any single input through the monitor's internal speakers.

Referring to the AMPx-D8 Series rear panel diagram ([Figure 2-7 on page 14](#)) and the front panel controls ([on page 8](#)), follow the instructions below by signal/connector type.

**Note:** For a complete description of each front panel control, refer to [Front Panel Controls on page 8](#).

For a complete description of each rear panel connector, refer to [Rear Panel Connectors on page 13](#).

## Monitoring an Analog Input

---

1. To monitor an analog signal, connect the analog input to the rear panel **Balanced Analog In** (DB-25) connector.
2. On the front panel, press the **Input** button until the LCD screen displays **Analog**.
3. Continue on to [Channel Selection and Mixing on page 24](#).

## Monitoring an AES Input

---

1. To monitor an AES signal, do one or both of the following:
  - Connect an unbalanced AES signal to the rear panel **AES/PCM In 1** (BNC), and/or
  - Connect a balanced AES signal to the rear panel **AES Bal In & Loop Out** (DB-25).
2. On the front panel, press the **Input** button until the LCD screen displays the corresponding input you want to monitor:
  - **AES1** for an unbalanced signal (connected to BNC 1).

- **AES2** for a balanced signal (connected to the DB-25).

**Table 2–9 AES Input to Channel Relationship**

AES BNC Connector	Channel Outputs
1	1 and 2
2	3 and 4
3	5 and 6
4	7 and 8

3. Refer to [Terminating/Unterminating Inputs on page 40](#) to check/set your termination settings.
4. Continue on to [Channel Selection and Mixing on page 24](#).

## Monitoring an SDI Input

---

1. To monitor an SDI signal, do one or both of the following:
  - Connect an SDI signal to the rear panel **SDI In 1** (BNC), or
  - Connect an SDI signal to the rear panel **SDI In 2** (BNC).
2. On the front panel, press the **Input** button until the LCD displays the corresponding input you want to monitor:
  - **SDI1** for a signal to the **SDI In 1** (BNC), or
  - **SDI2** for a signal to the **SDI In 2** (BNC).
3. Continue on to [Channel Selection and Mixing on page 24](#).

## Monitoring a Dolby Input

---

1. To monitor a Dolby signal, connect the Dolby input to the rear panel **Dolby AC-3 In 1** or **In 2** (BNC) connector.
2. Press the **Dolby** key (the key with double-D symbol next to it) to put the unit into bitstream mode.
3. On the front panel, press the **Input** until the LCD screen displays the Dolby input signal you want to monitor.

## Chapter 2 System Overview

### Channel Selection and Mixing

- **BSt1** for a signal to the **Dolby AC-3 In 1** (BNC), or
  - **BSt2** for a signal to the **Dolby AC-3 In 2** (BNC).
4. Refer to [Terminating/Unterminating Inputs on page 40](#) to check/set your termination settings.
  5. Continue on to [Channel Selection and Mixing](#) immediately below.

## Monitoring Dolby in SDI

---

To Monitor a Dolby signal embedded in SDI, follow the instructions below.

1. Connect the SDI signal with embedded Dolby to either SDI In 1 or SDI In 2.
2. Press the **Dolby** key (Double D symbol) to activate the bistream mode.
3. Press the **Input** key until the selected input (SDI1 or SDI2) is shown in the LCD.
4. Then press the **Group** button until the pair containing the Dolby signal is shown in the display (i.e., G1 3/4).

## Channel Selection and Mixing

**Note:** The level meters will operate automatically, displaying volume levels for each channel carrying an input signal.

To produce audio through the internal speakers, press each of the **Speaker Assign** buttons ( [on page 22](#)) until each channel is output through the speaker of your choice. See [Table 2-10](#).

**Table 2-10 Speaker Assign Button Functionality**

Button Press	LED Color	Speaker
1st	Steady Green	Left
2nd	Flashing Green/Amber	Both
3rd	Steady Amber	Right
4th	Off	Neither



---

**AES**  
**Example:**

Suppose you are monitoring an AES pair connected to the unbalanced **AES/PCM In 1**. When **AES1** is selected for input, the left channel of the AES pair will appear on the meter for Channel 1, and the right on Channel 2. Press the **Speaker Assign** button for Channel 1 until the Channel LED turns green. Press the **Speaker Assign** button for Channel 2 until the Channel LED turns amber. The left channel of the AES pair now sounds in the left speaker, and the right channel in the right speaker.

---



# CHAPTER 3

# Audio Configuration

---

## Introduction

### Overview

---

This chapter is the “how to” chapter. All topics listed below are sorted alphabetically for easy reference. For information about presets refer to [Chapter 4: Presets on page 43](#). For information about using the Dolby features, refer to [Chapter 5: Dolby on page 49](#).

### Topics

---

Topics	Page
Introduction	27
Analog Output Preference	28
Monitoring and Mixing Modes	29
Muting the Speakers	33
Phase Correlation	34
SDI Inputs	35
Selecting the Input Signal	38
Setting the Monitor’s Startup Configuration	39
Terminating/Unterminating Inputs	40

# Analog Output Preference

The Analog Output Preference determines how the **Selected/Downmix Analog Output** connectors and the **Metered Analog Output** connector (Figure 3-1 below) output the metered signals when either the DM1, DM2, or DM3 downmix options are selected.

The default setting is **Downmix**, which outputs the speaker assign with individual channel scaling (gain settings) intact as determined by the selected downmix. However, if you select **Discrete**, then all channels with the downmix are output from these connectors at full gain *without* scaling of the channels as determined by the selected downmix.

To change the analog output settings:

1. Hold the **Fn** button while pressing the **Setup** button.
2. Press the **Down** button until the LCD screens **AOutPref** as shown in Figure 3-1 below.

**Figure 3-1** Analog Output Preference LCD screen

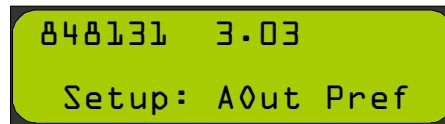

3. Pressing the **Enter** button displays either Figure 3-2 or Figure 3-3 depending on the current setting.

**Figure 3-2** Analog Output Preference Setting - Discrete

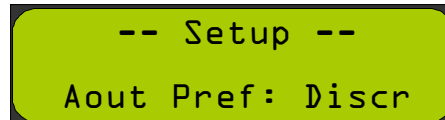

**Figure 3-3** Analog Output Preference Setting - Downmix

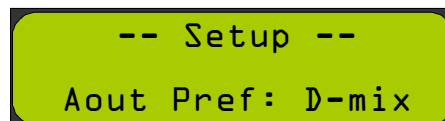

4. Press either the **Up** or **Down** arrow followed by the **Enter** button to change the setting, or press the **Escape** button to leave it as is.
5. Press the **Escape** button again to return to normal operation.

## Monitoring and Mixing Modes

### Arbitrary Mixing

1. Press any of the eight speaker assign buttons to activate the mixing (summing) feature. This mode is indicated by the LCD screen showing **MIX** in the upper right and left of the display. See [Figure 3-4](#) below for an example.

**Figure 3-4 LCD screen: Speaker Assign**

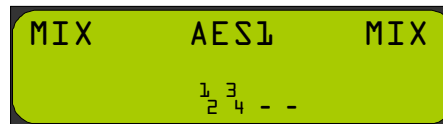

2. Each subsequent press of a speaker assign button assigns the selected channel to the left, both, right or neither speaker channel. All eight channels may be mixed/summed in this way. With each successive button press, the color of the associated speaker assign LED, and the mixing/routing of that channel, cycles through the following sequence

**Table 3-1 Speaker Assign Selection**

Button Press	Results
1st	Green (routed to left speaker only)
2nd	Alternating Green and Amber (routed to both left and right speakers)
3rd	Amber (routed to right speaker only)
4th	Off (not mixed or routed into either speaker)

## Single

---

This mode allows you to select one and only one signal for each speaker independently of the other speaker and is most useful when you are monitoring mono sources.

To select channels individually for each speaker:

1. Press the **Fn + Single** buttons to enable single channel selection.

**Figure 3-5 Single Channel Selection**



2. Press the **Left** button to cycle through the channel selections for the left speaker. Likewise, press the **Right** button to cycle through the channel selections for the right speaker.

## Pairs

---

This mode allows you to quickly assign one pair of channels to the speakers. The selections are limited to Channels 1-2, 3-4, 5-6, and 7-8. In all cases, the odd channel is sent to the left speaker, and the even channel to the right. This mode is most useful when you are monitoring stereo sources.

To select channel pairs for each speaker:

1. Press the **Fn + Pair** buttons to enable channel pair selection.

**Figure 3-6 Channel Pair Selection**



2. Use the **Left Up** or **Right Up** buttons to cycle through the channel pair selections.

## Downmix

---

This mode is most useful when multiple signals need to be mixed together and monitored at the same time. DM1-3 are designed for 5.1 surround sound signals, and assume a channel arrangement of (Channels 1-6 respectively):

- Left Front, Right Front,
- Center, LFE (Subwoofer),
- Left Surround, Right Surround.

4+4 Mode, Mix A, and Mix B are provided for other types of multi-channel monitoring needs.

1. Press the **Fn + Downmix** buttons to enable Downmix mode.
2. Press the **Left** or **Right** button to cycle through the seven available Downmix types to monitor through the speakers:

**Note:** None of the available **DM** downmix modes include Channel 4 because it normally carries the LFE channel which is below 200 Hz.

- **DM1:** This downmix is most suitable for a loudspeaker or headphone downmix of a multi-channel program. Left and left surround input channels mix into the left speaker, right and right surround input channels mix into the right speaker. Center input speaker assigns equally into both left and right speakers. Contribution of the surround channel mix is set by the **Surround Gain** entry in the Setup Menu. DM1 is equivalent to the Japanese ARIB Set 1 downmix formula. See [DM1 Mix Diagram on page 32](#).

**Figure 3-7 DM1 Mix Diagram**

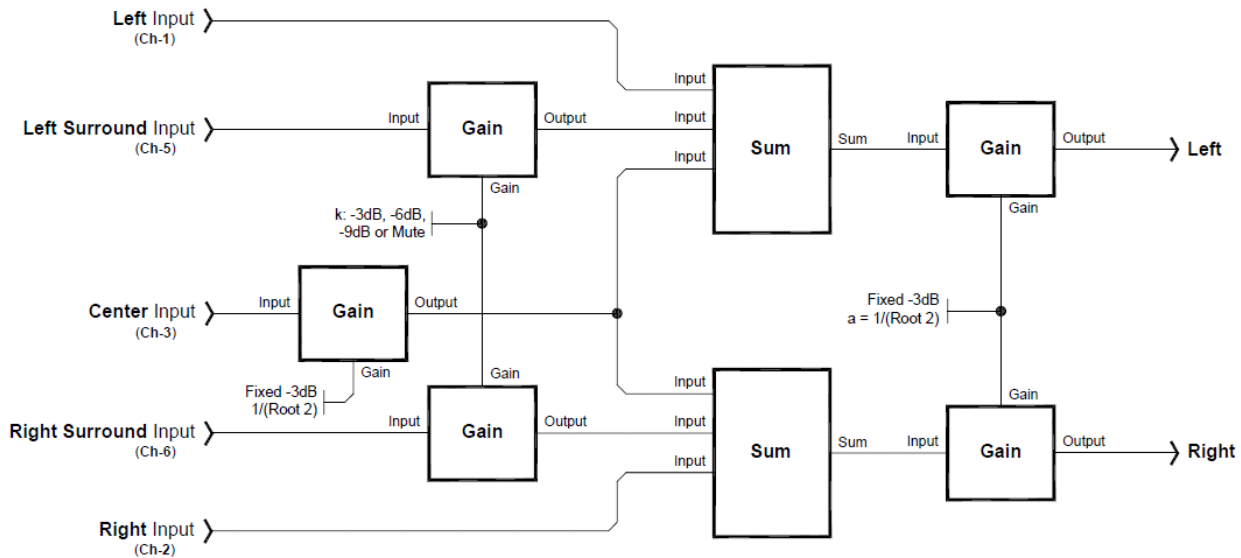

- **DM2:** You can use this downmix to create a two speaker assign that can be further decoded to multi-channel program by the use of an external surround decoder. Contribution of the surround speaker Assign is set by the surround level entry in the Setup Menu. DM2 is equivalent to the Japanese ARIB Set 2 downmix formula. See [Figure 3-8](#) below.

**Figure 3-8 DM2 Mix Diagram**

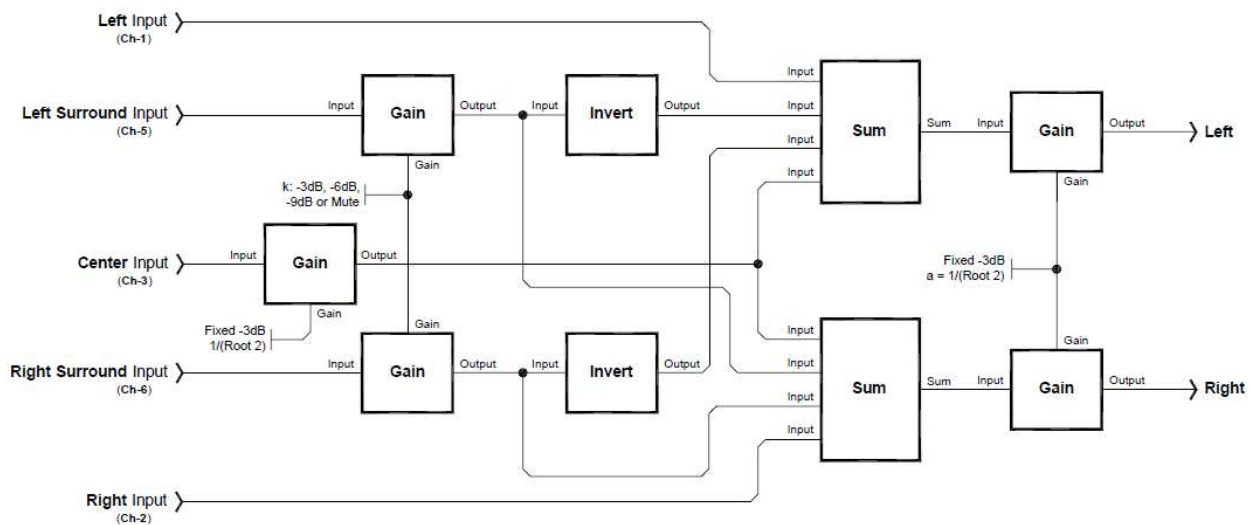



- **DM3:** This downmix is the same as DM1 except that the surround level is fixed at  $-3$  dB. DM3 is equivalent to the Japanese ARIB Set 3 downmix formula. See Figure 3–9 below.

Figure 3–9 DM3 Mix Diagram

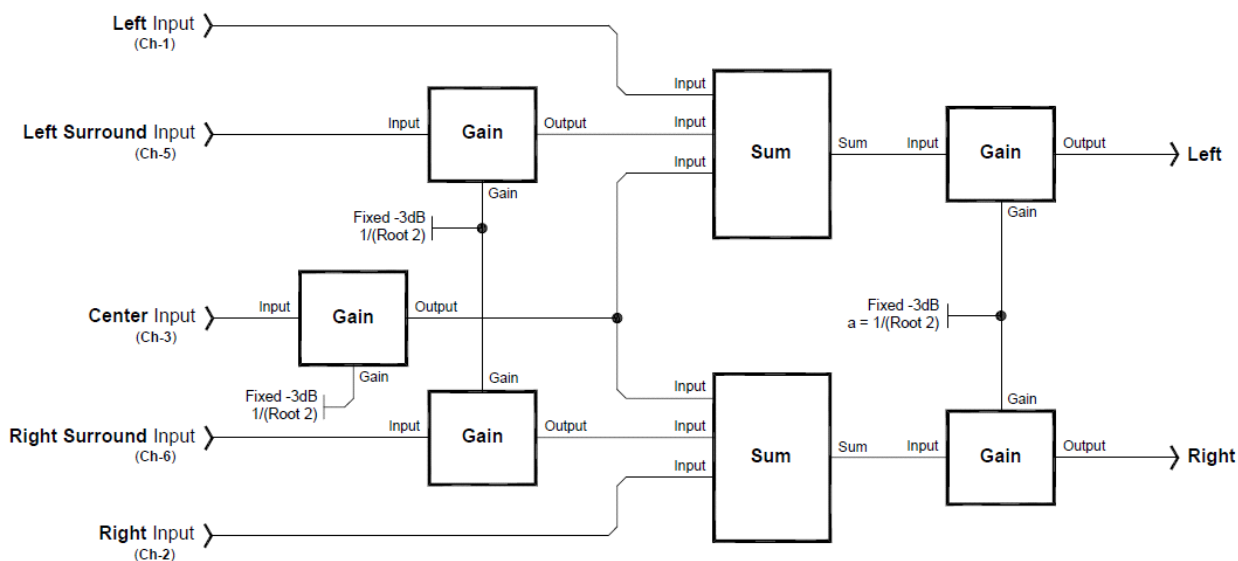

- **4+4:** In this downmix Channels 1 through 4 are summed to the left speaker and Channels 5 through 8 are summed to the right speaker.
- **MXA** and **MXB:** Select one of these two downmixes to custom mix by adding Channels 1 through 8 into the left or the right speakers using the **Speaker Assign** buttons.
- **MIX:** This mode appears whenever the **Speaker Assign** buttons are pressed. The selection made in this mode is lost whenever another mode is selected, or a preset is recalled. Presets saved in **MXA** or **MXB** mode are recalled in this mode.

## Muting the Speakers

The AMPx-D8 Series monitor provides two methods for muting the internal speakers:

1. Plug in a pair of headphones, or
2. Press the **Mute** button.

Pressing the **Mute** button allows you to step through three mute states and an unmuted state. When the system is in one of the mute states, all other information normally shown in the LCD such as the **Input Status Display** is disabled. In addition, all other buttons are displayed until you unmute the system. See [Table 3–2](#) below.

**Table 3–2 Mute Mode Functionality**

Button Press	Muted State
1st	Mutes both left and right speakers
2nd	Mutes the left speaker
3rd	Mutes the right speaker
4th	Returns the system to normal operation

Muting functions affect the signals to the speakers/headphones and the rear panel **Selected/Downmix Analog Output** connectors. Muting does not affect the Metered Analog Outputs except to defeat scaling. These outputs remain active even when the mute state is enabled.

**Note:** When the speakers are muted, the gain scaling of the **Metered Analog Outputs** is defeated so that no scaling is applied during unit muting. Refer to [SDI Inputs on page 35](#) for more information.

## Phase Correlation

1. Pressing the  $\phi$  button displays the phase correlation indicator in the LCD screen.

The average correlation (phase) for the signal going through the left speaker compared to the signal going through the right speaker is indicated by a stationary block appearing in one of three positions on the second line of the screen. A moving block indicates an instantaneous (short term sample) phase correlation. Each of the three positions has a different meaning.

- **Center:** Only one channel active, or zero (0) correlation between the two channels
- **Left (-):** Selected channels are out-of-phase (-1 correlation maximum)

- **Right (+):** Selected channels are in-phase (+1 correlation maximum).

With typical stereo program material, the moving block display is normal.

If the signals to the speakers are completely independent, they will have a correlation result of 0, and the block will be stationary in the center of the screen. See [Figure 3–10](#) below for an example.

**Figure 3–10 Phase Correlation Display**

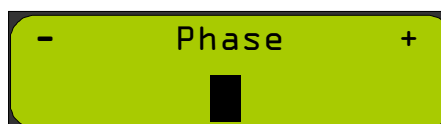

A mono in-phase signal fed to both right and left speakers would result in the block being in the right-most position indicating the left and right speaker signals are phase-identical.

2. Press any button to return to normal operation.

## SDI Inputs

### Selecting SDI Groups and Subgroups

---

#### Dolby Decode Mode Disabled

When you select either of the SDI inputs for monitoring while Dolby Decode mode is disabled, the **Group** button allows you to select which two, four-channel SDI audio groups to display in the level meters.

When you press the buttons quickly, the selection order follows that shown in [Table 3–3 on page 36](#).

**Table 3–3 SDI Group Select**

Button Press	Left Bar Graph Bank (1 through 4)	Right Bar Graph Bank (5 through 8)
1st	Group 1	Group 2
2nd	Group 3	Group 4
3rd	Group 1	Group 2
4th	Group 1	Group 3
5th	Group 1	Group 4
6th	Group 2	Group 3
7th	Group 2	Group 4
8th	Group 3	Group 4

1. Press the **Group** button quickly to select the group and then wait until the display flashes once.
2. Now press the **Group** button more slowly to toggle between **Group 1/2** and **Group 3/4** selections.

After this, rapid presses will again initiate the cycling as shown in [Table 3–3](#). Since the first two selections are more common choices, this features allows easy toggling between them.

## Dolby Decode Mode Enabled

When you select either of the SDI inputs for monitoring when Dolby Decode mode is enabled, the **Group** button allows you to select the SDI sub-group (two channels) to send to the Dolby decoder. You can select either of the two available sub-groups within any of the SDI audio Groups 1, 2, 3, or 4.

The embedded channels within an SDI signal are defined in [Table 3–4](#) below.

**Table 3–4 SDI Group Definitions**

SDI Group	SDI Sub-Group	Channels	Designation
Group 1	Sub-Group 1	1 and 2	G1 <sub>1/2</sub>
	Sub-Group 2	3 and 4	G1 <sub>3/4</sub>
Group 2	Sub-Group 1	1 and 2	G2 <sub>1/2</sub>
	Sub-Group 2	3 and 4	G2 <sub>3/4</sub>
Group 3	Sub-Group 1	1 and 2	G3 <sub>1/2</sub>
	Sub-Group 2	3 and 4	G3 <sub>3/4</sub>
Group 4	Sub-Group 1	1 and 2	G4 <sub>1/2</sub>
	Sub-Group 2	3 and 4	G4 <sub>3/4</sub>

**Example:** G1<sub>1/2</sub> will appear on the bottom left hand side of the LCD screen when the user wants to monitor a bitstream in the first sub-group of Group 1. This corresponds to Channels 1 and 2 of an ordinary PCM embedded audio signal. Similarly, G3<sub>3/4</sub> will appear when the user wants to monitor a bitstream in the second sub-group of Group 3.

Press of the **Group** button to cycle through each of the eight choices in the following order:

- G1<sub>1/2</sub>
- G1<sub>3/4</sub>
- G2<sub>1/2</sub>
- G2<sub>3/4</sub>
- G3<sub>1/2</sub>
- G3<sub>3/4</sub>
- G4<sub>1/2</sub>
- G4<sub>3/4</sub>

## Configuring for SDI Delay

**Important:** This function only works for SDI signal types.

Modifying the SDI delay value allows you to precisely synchronize the audio signal to a video signal.

To change the **SDI Delay** setting:

1. Hold the **Fn** button while pressing the **Setup** button.
2. Press the **Down** button until the LCD screens **SDI Delay** as shown in [Figure 3–11](#) below.

**Figure 3–11** SDI Delay in the Setup Menu

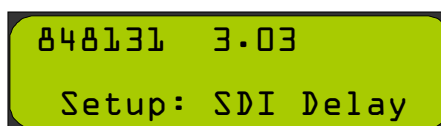

3. Press the **Enter** button to select the option. The LCD display to an image similar to that shown in [Figure 3–12](#) below.

**Figure 3–12 SDI Delay Setting**

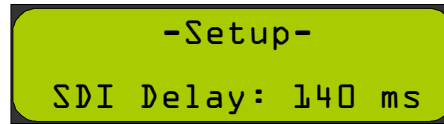

4. Press either the **Up** or **Down** buttons to select the delay in milliseconds from 10 to 170 for units equipped with a 919300 SDI De-embedder, or from 10 to 340 for units equipped with a 9193989 SDI De-embedder.
5. Press the **Enter** button to make your selection and return to the Setup Menu.
6. Press the **Escape** button to return to normal operation.

## Selecting the Input Signal

While the system is in normal operation, press the **Input** button to cycle through each of the five selections. The selection is enabled when it appears in the LCD screen. (Pressing the **Enter** button is not necessary.)

- Analog
- AES
  - **AES1** (Unbalanced)
  - **AES2** (Balanced)
- SDI (not available in the DA model)
  - **Auto.SDI** or **Auto.SDI2** if no signal is present
  - **SD.SDI** (signal is present and auto-detected)
  - **HD.SDI** (signal is present and auto-detected)
  - **3G.SDI** (signal is present and auto-detected)

# Setting the Monitor's Startup Configuration

You can configure the AMPx-D8 Series monitor to start up from a powered-off state, and automatically begin monitoring a particular input.

1. Press the **Fn + Setup** buttons.
2. Press the **Down** button until the LCD screens **Startup** as shown in [Figure 3-13](#) below.

**Figure 3-13 Startup Menu Option**

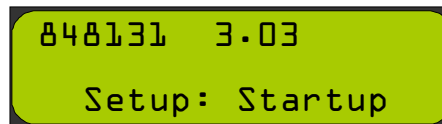

3. Press the **Enter** button to display the Startup list.
4. Press the **Up** or **Down** buttons to scroll through the startup options. Note that only those options that are available in your system will show up in the list.
  - Last Used
  - Analog
  - AES 1
  - AES 2
  - SDI 1
  - SDI 2
  - BSt1
  - BSt2
  - SDI 1 + DBY
  - SDI 2 + DBY
5. Press the **Enter** button to make your selection and return to the Setup Menu.
6. Press the **Escape** button to return to normal operation.

# Terminating/Unterminating Inputs

Each of the AES and bitstream inputs on the AMPx-D8 may be terminated or unterminated independently of each other. A given input should be terminated when the AMPx-D8 is the last receiving device in the signal path or is the only receiving device in the signal path. If the signal loops through the AMPx-D8 to another receiving device, the input should be unterminated in the AMPx-D8 (and terminated at the last device in the signal path). Terminating the signals properly improves signal integrity, and ensures the signal will be received correctly by all the devices in the signal chain.

In the AMPx-D8 monitors, the terminations are set to “Enabled” by default for all inputs.

To change the termination settings:

1. Hold the **Fn** button while pressing the **Setup** button.
2. Press the **Down** button once. The LCD should look similar to the image in [Figure 3-14](#) below.

**Figure 3-14 AES Termination Settings**

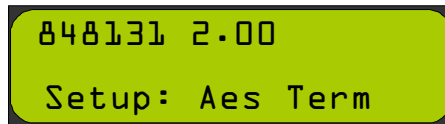

3. Press the **Enter** key. The LCD should now look like the image [Figure 3-15](#) or in [Figure 3-16](#).

**Figure 3-15 Termination Setting Currently Enabled**

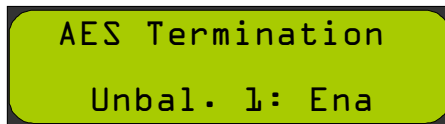

**Figure 3-16 Termination Setting Currently Disabled**

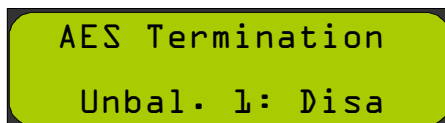



4. Press the **Up** or the **Down** buttons until the desired input is shown on the screen.
5. Press the **Enter** key to change the termination setting for that input.

**Important:** Repeat Steps 4 and 5 until all the inputs have been set according to your needs.

6. To exit the menu, press the **Up** or **Down** arrow buttons until **Save and Exit** appears in the LCD, as shown in [Figure 3–17](#) below.

**Figure 3–17**      **Saving and Exiting the Termination Settings**

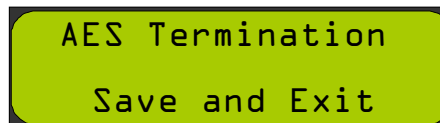

7. To exit the **Setup** menu without saving your changes, press **Escape**.

In a system with a Dolby card, the termination selection order is:

- Unbalanced 1
- Unbalanced 2
- Unbalanced 3
- Unbalanced 4
- Balanced 1
- Balanced 2
- Balanced 3
- Balanced 4
- Bitstrm. 1
- Bitstrm. 2
- Save and Exit



# CHAPTER 4

# Presets

---

## Introduction

### Overview

---

This chapter describes how to create, recall, modify, and erase presets. It also discusses using Preset mode for fast system configuration.

### Topics

---

Topics	Page
Introduction	43
What are Presets?	44
Methods of Accessing the Presets	44

# What are Presets?

The AMPx-D8 is an incredibly flexible tool for monitoring multiple audio streams. You can configure the entire system to function exactly the way you want it to for your specific application. You can store a complete system configuration into a preset. After saving one or more presets, you can quickly scroll through them with the press of a single button. The AMPx-D8 allows you to store up to 10 presets (numbered 0 through 9).

## Methods of Accessing the Presets

### Setup Menu

---

All presets can be stored, recalled, or erased through the Setup menu.

1. Press **Fn+Setup** to enter the Setup menu.
2. Use the **Up** and **Down** arrow buttons to select **Save Preset**, **Erase Preset**, or **Recall Preset**.
3. Then press the **Enter** button.

Each of these menu items is described more fully in [Chapter 6: Setup Menu on page 55](#).

### Preset Mode

---

This mode of operation is intended for situations where a number of pre-defined unit configurations is all you need. This allows even the most non-technical person to quickly scan through a list of sources to monitor, without having to understand the operation of the rest of the unit, or which source is plugged into which input of this unit.

In Preset mode, the **Input** button cycles through the defined presets. With Preset mode enabled, you can recall a preset by pressing only the **Input** button to access each stored preset by name, rather than by signal type.

**Note:** When this mode is enabled, you can no longer directly select the inputs by the input type (e.g., AES 1, SDI 2, analog, and so on). The inputs are accessed only indirectly through the presets in this mode. To access the inputs by input type, you must first disable Preset mode.

## Enabling/Disabling Preset Mode

To enable or disable Preset mode:

1. Press **Fn+Setup**.
2. Use the **Up** and **Down** arrow buttons until **PSet Mode** appears in the LCD window and press **Enter**.

**Note:** This selection will not appear if all the presets are empty. In this case, you will need to store at least one preset to enable this menu item.

3. Press the **Up** and **Down** arrow buttons to toggle between **Disa** (disabled) and **Ena** (enabled). Press **Enter** to accept the new setting, or press **Escape** to cancel the change. Either way, you will be returned to the Setup menu.
4. Press **Escape** again to return to normal operation.

## Recalling a Preset

If Preset mode is enabled, press **Input** to recall the first available preset. Subsequent presses will cycle through all the available presets.

## Speaker Assign/Preset Buttons (Presets 1 through 4 Only)

---

Presets 1 through 4 get special attention. You can recall, save, or overwrite them simply by pressing **Fn+Preset x** (where x represents the corresponding **Speaker Assign** button immediately above or below the meters on the left side of the unit). In the following examples, we'll be using Preset 1.

#### Saving a Preset

1. Press **Fn+Preset 1**.

If Preset 1 is currently empty, the system will prompt you to save the current unit configuration to Preset 1.

2. Name the preset by using the **Up** and **Down** arrow buttons to scroll through the available list of characters. Press **Enter** to accept each character.
3. When you're done entering all the characters, scroll until **\_DONE\_** appears in the window, and press **Enter**.

**Note:** **\_DONE\_** is located between the lowercase letters and before the numbers.

#### Recalling a Preset

If, after pressing **Fn+Preset 1**, the preset is *not* empty, the system will prompt you to recall Preset 1, and Preset 1's name will appear in the LCD. If you press **Enter**, the system will recall the preset.

#### Overwriting a Preset

If, after pressing **Fn+Preset 1**, the preset is *not* empty, the system will prompt you to recall Preset 1, and Preset 1's name will appear in the LCD.

1. If you press **Escape** while the preset recall prompt is showing, the system will ask you if you want to overwrite the preset. If you want to overwrite the preset with the unit's current settings, press **Enter**.
2. Press **Enter** to continue.
3. **Save Old Name?** will appear, with the selected preset number and current name below it. If you wish to use the name displayed, press **Enter**, and skip the rest of the following instructions. Your current settings are now stored in the selected preset.

Otherwise, if you wish to enter a new name, continue on with Step 4 below.

4. Press **Escape**.

5. Name the preset by using the **Up** and **Down** arrow buttons to scroll through the available list of characters. Press **Enter** to accept the character; repeat the process until all the characters have been entered.
6. When all the characters have been entered, scroll until **\_DONE\_** appears in the window, and press **Enter**.

**Note:** **\_DONE\_** is located between the lowercase letters and before the numbers.

If you do not want to overwrite the preset, press **Escape** again, and the unit will be returned to normal operation without recalling Preset 1 or modifying it in any way.





# CHAPTER 5

# Dolby

---

## Introduction

### Overview

---

This chapter describes how to enter Dolby Decode mode to get the most out of your Dolby signal.

### Topics

---

Topics	Page
Introduction	49
Dolby Input Source Selection	50
Dolby Decoding	50
Dolby Metadata	52

# Dolby Input Source Selection

1. Enter Dolby Decode mode by pressing the **Dolby** (double D symbol) button.
2. Press the **Input** button to select the source. (The selection is enabled when it appears in the LCD screen.) Each press of the **Input** button cycles through each of the four selections:
  - BSt1 (Bitstream 1)
  - BSt2 (Bitstream 2)
- SDI (not available in the DA model)
  - **Auto.SDI** or **Auto.SDI2** if no signal is present
  - **SD.SDI** (signal is present and auto-detected)
  - **HD.SDI** (signal is present and auto-detected)
  - **3G.SDI** (signal is present and auto-detected)
3. If one of the SDI inputs is selected, pressing the **Group** button selects the de-embedded SDI pair to be decoded.

**Figure 5-1**      **Dolby Input Source Selection**

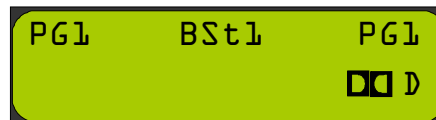

## Dolby Decoding

When you connect a valid bitstream containing at least one multi-channel program (such as a 5.1 channel surround type) to the AMPx-D8 Series unit, it enters a default multi-purpose monitoring mode, the Auto-Monitor Multi-Channel Mode. While this mode initially sends a downmix to the unit's speakers, this mode also allows you to select pairs of channels from the multi-channel program in a Dolby bitstream.

**Note:** You can only enter this mode as described below; it cannot be selected.

Use the **Left** or **Right** button to scan through the list of programs available in the selected bitstream. Multi-channel programs will allow you to scroll through the pairs of the program to isolate individual channels with the **Balance** knob or mute features. Channels that are not enabled per Dolby specifications are not selectable. The appropriate speaker Assign LEDs above the bar graph meters will light to indicate which channels are selected to the left and right sides of the unit's stereo speaker array. While a channel pair is selected in this monitoring mode, the LCD screen will indicate the selected channel pairs by showing the first channel (of the selected pair) in the upper left of the LCD screen and the second channel in the upper right. When the downmix is selected, the LCD screen will show **PgN** on both upper left and right corners of the LCD screen (where **N** is the Dolby-assigned program number).

**Figure 5–2**      **Dolby, Bitstream 1, Program 1**



When Dolby Decode mode is enabled (and a valid signal is detected), Dolby D will show up on the bottom right hand corner of the LCD screen for Dolby Digital signals, respectively. Dolby bitstreams can be fed into Dolby **BSt1** or **BSt2** (a.k.a. bitstream inputs, labeled as **Dolby AC3 In**), or can be embedded into any audio pair of an SDI signal present on **SDI In 1** or **In 2**.

Dolby Digital allows only one program. The number available depends on the type of signal being monitored. See the [Table 7–5: Dolby Main Output Channel Assignments on page 73](#) for a full list of possible program channel assignments for Dolby Digital bitstreams. The two types of bitstreams accepted at the Dolby inputs are Dolby Digital and PCM.

## PCM

If the signal being monitored is a PCM (AES/EBU) signal, then only one monitoring mode is available: **PG1**. In this mode Channel 1 is sent into the left speaker and Channel 2 is sent into the right speaker. See

[Table 7–5 on page 73](#) for a table of Dolby main output channel assignments.

## Dolby Metadata

Pressing the **MData** button when Dolby Decode mode is enabled displays the metadata of the selected Dolby Digital channels being monitored. Each press of the **MData** button cycles through the properties of the selected Dolby channels in (approximately) the following order:

- Audio encoding format and bit depth (e.g., Dolby AC-3, 20 bit)
- Data rate (e.g., 32, 384, 640)
- Audio coding (e.g., 3/2, 2/0)
- Dialog normalization (0 to –31 dB)
- Bitstream mode (e.g., complete/main, music/effects)
- Surround mode (e.g., srnd not indicated, not Dolby srnd)
- Surround and center mix level (e.g., -3.0 dB, -6.0 dB)

Some examples of how Dolby metadata information is displayed in the LCD screen are shown in [Figure 5–3 on page 53](#) and [Figure 5–3 on page 53](#).

Figure 5-3 Normal Operation - Dolby D

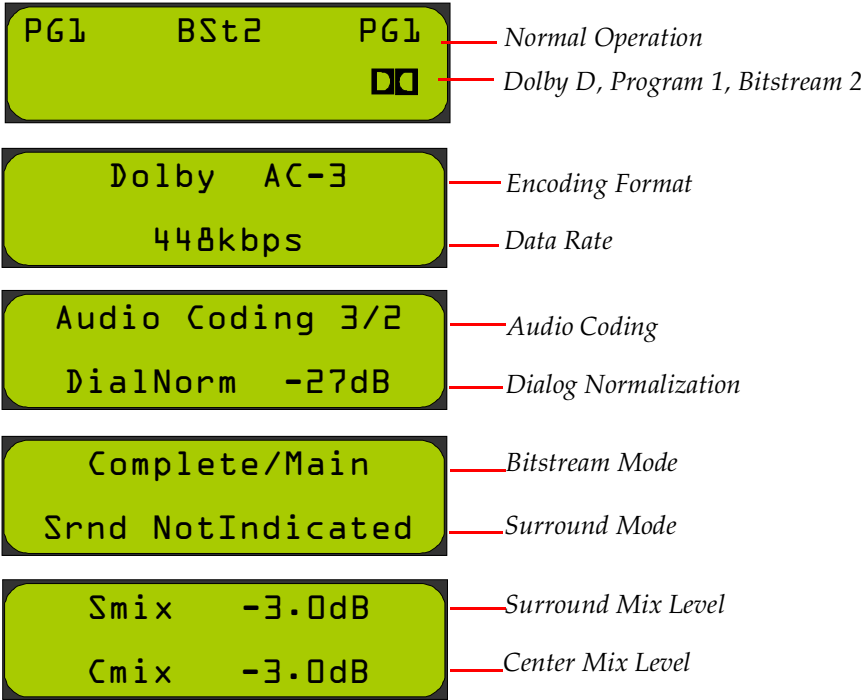



# CHAPTER 6

# Setup Menu

---

## Introduction

## Overview

---

This chapter explains the options in the Setup menu. [Figure 6–1 on page 56](#) provides a structural overview.

## Topics

---

Topics	Page
Introduction	55
Accessing Setup Mode	56
Analog Output Preference Mode	58
Recalling a Preset	58
Saving a Preset	59
Preset Mode	63
Erasing a Preset	64
SDI Delay	65
Startup	65
Surround Gain	66
Bitstream Detection	66
Phase Bits	67

# Accessing Setup Mode

Figure 6-1 Setup Menu Tree

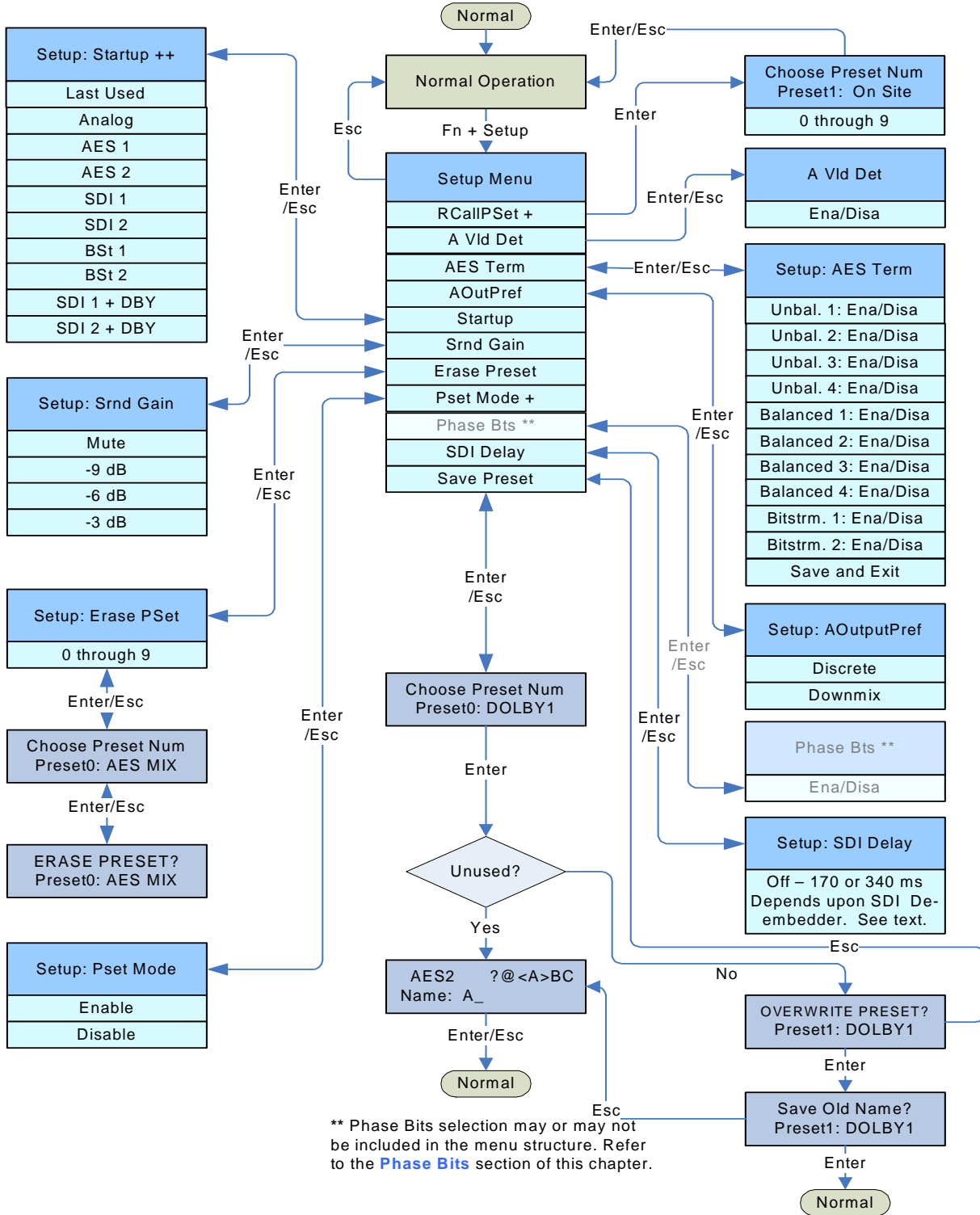



1. Enable Setup mode by pressing and holding the **Fn** button and then pressing the **Setup** button. This mode is used to change unit features.
2. You can step through the menu selections and parameters using the **Up** and **Down** buttons.
3. Press the **Enter** button to save your selections. To cancel the option and exit the menu, press the **Escape** button.

The current options in Setup Mode (as shown in [Setup Menu Tree on page 56](#)) are:

- Preset Recall (**RCallPSet**)
- Preset Save (**SavePSet**)
- Preset Mode (**PsetMode**)
- Preset Erase (**ErasePSet**)
- SDI Delay (only available for the 3G model)
- Surround Gain (**Srnd Gain**)
- Startup
- Analog Output Preference (**AOutPref**)

After entering the Setup Menu, the display will indicate the software, version number, and the menu selection: **RCallPSet** (if presets are saved).

**Table 6-1 Up Button List**

Pressing the Up Button the...	Changes the Display to...
1st time	<b>SavePSet</b>
2nd time	<b>PSetMode</b> (if presets are saved)
3rd time	<b>ErasePset</b> (if presets are saved)
4th time	<b>SDI Delay</b> (3G model only)
5th time	<b>Srnd Gain</b>
6th time	<b>Startup</b>
7th time	<b>A-OutPref</b>
8th time	<b>RCallPSet</b>

To select the current option, press the **Enter** button.

To exit Setup Mode, press the **Esc** button.

**Note:** The **RCallSet**, **PSetMode**, and **ErasePSet** options will not be available if a preset has not been previously saved to the unit. See [Saving a Preset on page 59](#) for how to save a preset of the current unit configuration.

## Analog Output Preference Mode

To change the Analog Output Preference, select **AOutputPref** and then press the **Enter** button.

This entry within the Setup menu is used to determine how the **Selected/Downmix Analog Out** and **Metered Analog Out** connectors on the rear panel output the metered signal when any of the DM1, DM2, or DM3 downmix selections is enabled.

The default setting is **Downmix**, which outputs the speaker assign with individual channel scaling (gain settings) intact as determined by the selected downmix (DM1, DM2, or DM3). In addition, the channels are summed at unity gain into the speakers and headphones. However, if **Discrete** is selected, then all channels within the downmix are output from these connectors at unity gain without scaling of the channels as determined by the selected downmix. For example, the center channel scaling is -3dB, and the surround channel scaling is set in the Setup menu.

## Recalling a Preset

1. Press the **Fn + Setup** button to display the **Setup** menu.
2. Press the **Up** button to display **RCallPSet**.
3. Press the **Enter** button to select this option.

**Figure 6–2**      **Recalling an Existing Preset**

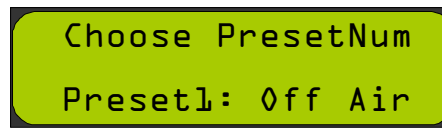

4. Press the **Up** and **Down** buttons to scroll through the presets.

In the example above (Figure 6–2), Preset 1 is called **Off Air**. If a particular preset is not assigned, it will be indicated as **Unused**, as shown in Figure 6–3 below.

**Figure 6–3**      **Creating a New Preset**

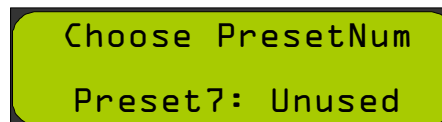

5. Press the **Enter** button with the desired preset displayed to recall that preset. The unit returns to normal operation, reconfigured according to the settings in that preset.

## Saving a Preset

1. Press the **Fn+Setup** buttons to display the Setup menu.
2. Press either the **Up** or **Down** buttons to display **Save Preset**.
3. Press the **Enter** button.

### Decision Point:

If you want to create a brand new preset, continue on to [Creating a New Preset on page 60](#).

Otherwise, if you want to overwrite an existing preset, continue on to [Overwriting an Existing Preset on page 61](#).

## Creating a New Preset

**Note:** To cancel the procedure at any time during this process, press the **Escape** button and the preset will not be saved and the unit will return to normal operation.

1. Press either the **Up** or **Down** buttons to choose any preset labeled **Unused**.

**Figure 6-4 Choose an Unused Preset**

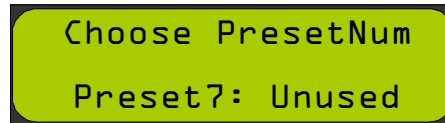

2. Press the **Enter** button to display a prompt for a new preset name as shown in [Figure 6-5](#).

**Figure 6-5 Assigning the Name of a Preset**

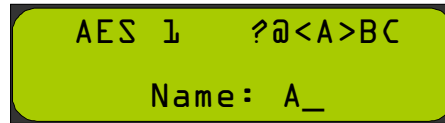

3. Scroll through letters (and symbols) using the **Left** and **Right** buttons. Press the **Enter** button to accept the current letter shown in the display and move to the next letter. Repeat this procedure until the display shows the name you want to use for this preset.

**Note:** Pressing the **Enter** button may display multiple letters, but the only one that changes will be the one immediately to the left of the underscore. As a result, it may be necessary to start the procedure over again if too many characters appear in the display.

**Figure 6-6 Completed Preset Name Selection**

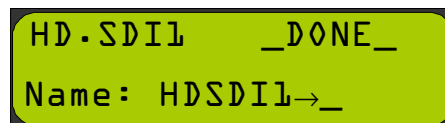

Naming will automatically end after you select eight characters, or when you press the **Enter** button when **\_DONE\_** appears on the display. See [Figure 6-6](#) above.

**Note:** The **\_DONE\_** selection comes before the numerals, and follows the lower case alphabet. The character order is the order of ASCII characters.

After naming the preset, the current state of the system is saved under that name and preset number, and the system returns to normal operation.

**Important:** This concludes the procedure for creating a new preset.

## Overwriting an Existing Preset

1. Press either the **Up** or **Down** buttons to choose any preset that is *not* labeled **Unused**.

Choosing an already used preset will display a warning to the user that they are about to overwrite the preset, as shown in [Figure 6-4](#) below.

**Figure 6-7**      **Overwriting a Preset**

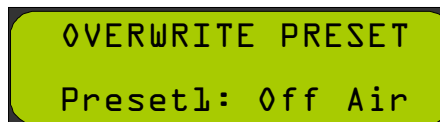

```
OVERWRITE PRESET
Preset1: Off Air
```

2. Press the **Enter** button to display **Save Old Name?** ([Figure 6-8 on page 61](#)) with the selected preset number and current name below it. If you wish to use the name displayed, press **Enter**, and skip the rest of the following instructions. Your current settings are now stored in the selected preset.

**Figure 6-8**      **Save Old Name?**

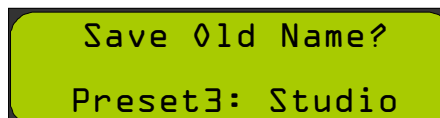

```
Save Old Name?
Preset3: Studio
```

## Chapter 6 Setup Menu

### Saving a Preset

3. Pressing the **Enter** button keeps the old name for the new preset and returns the unit to normal operation.

**Important:** This concludes the procedure for overwriting an existing preset with the same name.

Pressing the **Escape** button displays a prompt for a new preset name as shown in Figure 6–9 below.

**Figure 6–9** Save New Name?

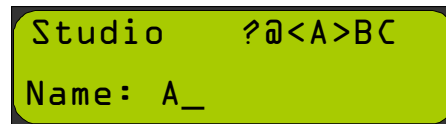

4. Scroll through letters (and symbols) using the **Left** and **Right** buttons. Press the **Enter** button to accept the current letter shown in the display and move to the next letter. Repeat this procedure until the display shows the name you want to use for this preset.

**Note:** Pressing the **Enter** button may display multiple letters, but the only one that changes will be the one immediately to the left of the underscore. As a result, it may be necessary to start the procedure over again if too many characters appear in the display.

Naming will automatically end after you select eight characters, or when you press the **Enter** button when **\_DONE\_** appears on the display.

**Note:** The **\_DONE\_** selection comes before the numerals, and follows the lower case alphabet. The character order is the order of ASCII characters.

After naming the preset, the current state of the system is saved under that name and preset number, and the system returns to normal operation.

**Important:** This concludes the procedure for overwriting an existing preset with a new name.

# Preset Mode

This mode of operation is intended for situations where a number of pre-defined unit configurations is all you need. This allows even the most non-technical person to quickly scan through a list of sources to monitor, without having to understand the operation of the rest of the unit, or which source is plugged into which input of this unit.

In Preset mode, the **Input** button cycles through the defined presets. With Preset mode enabled, you can recall a preset by pressing only the **Input** button to access each stored preset by name, rather than by signal type.

**Note:** When this mode is enabled, you can no longer directly select the inputs by the input type (e.g., AES 1, SDI 2, analog, and so on). The inputs are accessed only indirectly through the presets in this mode. To access the inputs by input type, you must disable Preset mode first

To enable or disable Preset mode:

1. Press **Fn+Setup**.
2. Use the **Up** and **Down** arrow buttons until **PSet Mode** appears in the LCD window and press **Enter**.

**Note:** This selection will not appear if all the presets are empty. In this case, you will need to store at least one preset to enable this menu item.

3. Press the **Up** and **Down** arrow buttons to toggle between **Disa** (disabled) and **Ena** (enabled). Press **Enter** to accept the new setting, or press **Escape** to cancel the change. Either way, you will be returned to the Setup menu.
4. Press **Escape** again to return to normal operation.

# Erasing a Preset

This menu command allows you to erase a stored preset. Pressing the **Enter** button will allow the user to choose a preset to erase.

**Figure 6-10 Erasing a Preset - Choose the Preset Number**

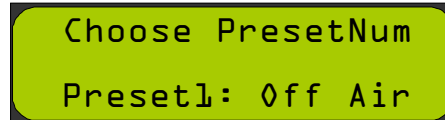

```
Choose PresetNum
Preset1: Off Air
```

The **Left** and **Right** buttons select from among the available presets. Once you press the **Enter** button to select a preset, the system will warn you that the preset will be erased.

**Figure 6-11 Erasing a Preset - Confirmation**

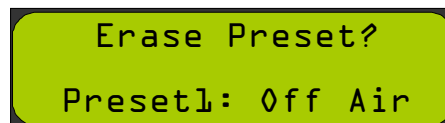

```
Erase Preset?
Preset1: Off Air
```

Pressing the **Enter** button will erase that preset. Pressing the **Esc** button will not erase that preset. In either case, control returns to the menu to choose another preset to erase.

**Figure 6-12 Erasing a Preset - Select the Preset to Erase**

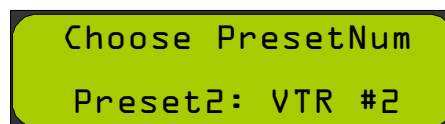

```
Choose PresetNum
Preset2: VTR #2
```

Press the **Esc** button to exit Setup Mode and return to Normal Monitoring Mode.



# SDI Delay

**Important:** This menu item is not available if this unit has no de-embedder card.

This feature allows you to change the amount of delay added to the de-embedded audio signals from the SDI inputs. This allows you to compensate for video processing delays in external video signal chains and monitors. This selection delays the monitored SDI audio and the de-embedded SDI AES signals, but does not affect the reclocked SDI output in any way.

**Figure 6-13** SDI Delay

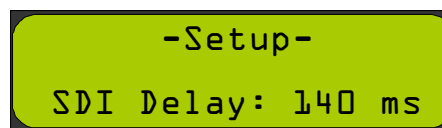

Step through settings using the **Up** or **Down** button, select 140 ms (for example). To accept, press the **Enter** button. Press the **Esc** button to exit Setup Mode and return to Normal Monitoring Mode.

# Startup

The **Startup** entry within the Setup Menu determines the input used by the unit at power up. When set to **Last Used**, the unit will power up the same way that the unit was before power was interrupted. If instead you want to have the unit start up every time with the same input selected, repeatedly press the **Up/Down** buttons until the desired input is shown in the LCD. Save the selection by pressing the **Enter** button. Press the **Esc** button to exit Setup mode and return to normal operation.

# Surround Gain

To change surround gain, select **Srnd Gain** and then press the **Enter** button.

**Figure 6-14 Erasing a Preset**

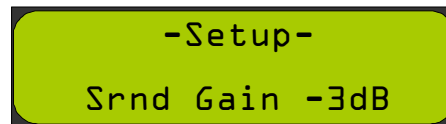

Step through settings using the **Up** or **Down** buttons, select -9dB (for example). To accept, press the **Enter** button. To exit without saving, press the **Esc** button.

**Important:** Surround gain adjustments are only effective for downmixes DM1 and DM2. In downmix DM3 the surround gain is fixed.

# Bitstream Detection

The unit will now mute an input pair if it detects the presence of a non-PCM stream (such as a Dolby or DTS bitstream) on that pair. The unit detects bitstreams with two methods:

- A. Preamble detection
- B. Not-Audio AES Channel status flag is asserted

In terms of Method A, encoded bitstreams contain key data sequences that identify the type of encoding used. These sequences are known as preambles (see the SMPTE 337 and 338 standards). This unit can only detect 16-bit preambles. For example, a 20-bit Dolby E stream would be passed as PCM audio, instead of being flagged as an encoded stream. This method is always employed.

In terms of Method B, the upstream equipment must either assert or de-assert this flag. Unfortunately, not all equipment does this correctly. In those cases where the channel status flag is set incorrectly, you may need to disable this method of bitstream detection. This can be done using the setup menu item **A Vld Det**. When enabled (**Ena**), Method B

is used to detect bitstreams. When disabled (**Disa**), Method B is not used to detect bitstreams. If your unit is muting PCM streams, set this item to **Disa**. If encoded bitstreams are getting through to the speakers, set this item to **Ena**.

## Phase Bits

For units with SDI de-embedder cards installed, there may or may not be a menu item available, entitled Phase Bts, which stands for phase bits. If this menu item is not available, then the presence or lack of proper phase bits is ignored and the product decodes audio properly regardless of whether other attached equipment is setting the bits correctly.

However, if this menu item is available, then it must be set according to the capabilities of the attached equipment. These are bits that are embedded in SDI streams that allow the audio sample rate to be independent of the video pixel clock, and they are required by the latest SMPTE standards. However, not all equipment implements these bits correctly. Normally, this menu item should be left in the Ena (enabled) setting, which means the phase bits are being used to properly time the audio samples that are being de-embedded.

If you experience interrupted or garbled audio from the SDI de-embedder, try setting this to **Ignor** (ignore), which means the embedded phase words are ignored. If this fixes the garbled audio, please contact the manufacturer of the upstream equipment to determine if any firmware updates are available for it. In cases where phase bits are not embedded at all, or if this menu item is set to **Ignor**, the pixel clock will be used as the reference for the de-embedded audio sample rate.



# CHAPTER 7

# Features and Specifications

---

## Introduction

### Overview

---

This chapter details the features of each of the monitors in the series and provides the technical specifications. It also outlines the distinctions between models.

### Topics

---

Topics	Page
Introduction	69
Features	70
Specifications	71
Technical Functional Overview	73

# Features

## Common Features

---

The AMPx-D8 Series audio monitors provide a complete, exceptionally high quality Dolby Digital (AC-3), 3G/HD/SD-SDI, PCM and analog stereo audio monitoring solution. A significant feature is the ability to process and monitor up to eight channels from a Dolby Digital (AC-3) bitstream, a 3G-SDI, HD-SDI and/or SD-SDI bitstream, two sets of four AES/EBU signal pairs (balanced and unbalanced) or eight analog channels. Eight high-resolution, 53-segment, tri-color, LED bar graph audio level meters provide accurate and instantaneous visual level monitoring at a glance.

- Space-saving 2 RU
- Dolby AC-3, AES/EBU, and analog signal monitoring
- Four de-embedded AES balanced or unbalanced outputs
- (Eight channels) from two selected SDI groups
- Four AES/EBU balanced inputs and loop-throughs on a DB-25 connector
- Eight analog inputs on a balanced DB-25 connector
- Eight analog outputs on a balanced DB-25 connector
- Comprehensive multi-channel to stereo downmix capability
- Unit configuration stored while unit is switched off
- Storage for ten preset monitoring settings for easy recall
- Phase (polarity) correlation display of selected channels
- LCD status display on front panel
- Volume and balance controls
- Eight high-resolution 53-segment tri-color LED bar graph level meters with simultaneous PPM dot over VU bar
- Headphone output
- Software is field upgradable

## Model Distinctions

**Table 7-1 Model Functional Distinctions**

Model	AES	Analog	SD-SDI	HD-SDI	3G	Dolby D
AMPx-D8DA	✓	✓				✓
AMPx-D8MDA-3G	✓	✓	✓	✓	✓	✓

## Specifications

**Table 7-2 Specifications for the AMPx-D8 Series Monitors**

Specification	Value
Analog Input Impedance	27K $\Omega$ balanced, minimum
AES Input Configuration	110 $\Omega$ balanced, 75 $\Omega$ unbalanced
Analog Input Overload	+24 dBu balanced
Analog Reference	+8, +6, +4, or 0 dBu
Digital Reference	-20, -18, or -9 dBFS
Meter Dynamics (AES Scale)	VU and PPM
Level Meter Scale (standard)	AES <sup>a</sup>
AES Input Sampling Rate D to A Converter	32 to 48 kHz, auto-selected 24-bit low jitter
Peak Acoustic Output (at 2 ft.)	104 dB SPL
Acoustic Distortion	6% or less at worst case frequencies above 140 Hz including cabinet resonance; typically < 1.5%
Electrical Distortion	<0.15% at any level below limit threshold
Response, 6th Octave	80Hz to 18 KHz $\pm$ 5 dB (-10 dB at 55 Hz, 21 kHz)
Distortion, Electrical	<0.15% at any level below limit threshold
Hum and Noise, Analog	Better than 68 dB below full output
Converted Analog Out THD	<0.008%
Magnetic Shielding	<1 Gauss any adjacent surface
Power Consumption	72 $\Omega$ max
AC Mains Input	100 to 240 VAC, 50 to 60 Hz

<sup>a</sup> Other level meter scales are available at time of manufacture including BBC, DIN, and others. Contact Wohler for more information concerning alternate scales.

**Table 7–3 Size-Specific Specifications for the AMPx-D8 Series Monitors**

Specification	AMP1s	AMP2s
Rack Height	1RU	2RU
Shipping Weight	18 lbs. (8.20 kg)	22 lbs. (9.98 kg)
Dimensions	1.75" x 19" x 11" (4.5 mm x 483 mm x 30 mm)  (Depth, including controls and knobs, is 13.5" [342.9 mm])	3.5" H x 19" W x 12.5" D (89 mm x 483 mm x 317.5 mm)  (Depth, including controls and knobs, is 14" [355.6 mm])
Level Meter Segments	25 segments	53 segments
Power Output	High Frequency: 5W (7W Peak) RMS (each channel); Low Frequency: 11W RMS (16W Peak)	RMS Each Side: 14W Transient/10W Continuous; RMS Bass: 35W Transient/25W Continuous
Peak Acoustic Output @ 2'	98 dB SPL	104 dB SPL
Acoustic Frequency Response	80 Hz - 20 kHz ( $\pm 5$ dB); (-10 dB @ 50 Hz, 22 kHz)	80 Hz - 16 kHz ( $\pm 5$ dB); (-10 dB @ 40 Hz, 22 kHz)
Acoustic Distortion	8% or less worst case frequencies above 180 Hz including cabinet resonance, typically < 2%	6% or less at worst case frequencies above 120 Hz including cabinet resonance, typically < 1.5%
Hum and Noise	Better than -68 dB below full output	Better than -68 dB below full output

**Table 7–4 Functionality-Specific Specifications for the AMPx-D8 Series Monitors**

Specification	DAs	3Gs
Audio Phase Data (SMPTE 299-2009)	May optionally be ignored in units equipped with a 919300 SDI De-embedder. Always ignored in units equipped with a 919398 SDI De-embedder.	
Inputs	<ul style="list-style-type: none"> <li>• AES (D-Sub 25, 4 BNC)</li> <li>• Analog (D-Sub 25)</li> <li>• Dolby (2 BNC)</li> </ul>	<ul style="list-style-type: none"> <li>• AES (D-Sub 25, 4 BNC)</li> <li>• 3G/HD/SD-SDI (2 BNC)</li> <li>• Analog (D-Sub 25)</li> <li>• Dolby (2 BNC)</li> </ul>



**Table 7–4 Functionality-Specific Specifications for the AMPx-D8 Series Monitors**

Specification	DAs	3Gs
Outputs	<ul style="list-style-type: none"> <li>Metered Analog (DB-25)</li> <li>Selected Downmix/ Analog Out (Left and Right, XLR-M)</li> <li>AES Bal In/Loop Out (DB-25)</li> </ul>	<ul style="list-style-type: none"> <li>Metered Analog (DB-25)</li> <li>3G/HD/SD-SDI Re-Clocked (BNC)</li> <li>AES Unbalanced Out from SDI (HD-15)</li> <li>(Optional) Balanced AES Out from SDI Input (DB-25)</li> <li>Selected Downmix/ Analog Out (Left and Right, XLR-M)</li> <li>AES Bal In/Loop Out (DB-25)</li> </ul>

**Table 7–5 Dolby Main Output Channel Assignments**

Dolby Digital Coding Mode	Main Output Channel Assignment							
	Ch 1	Ch 2	Ch 3	Ch 4	Ch 5	Ch 6	Ch 7	Ch 8
3/2L (Dolby Digital)	0L	0R	0C	0LFE	0Ls	0Rs	none	none
3/2 (Dolby Digital)	0L	0R	0C	none	0Ls	0Rs	none	none
2/2L (Dolby Digital)	0L	0R	none	0LFE	0Ls	0Rs	none	none
2/2 (Dolby Digital)	0L	0R	none	none	0Ls	0Rs	none	none
3/1L (Dolby Digital)	0L	0R	0C	0LFE	0S	none	none	none
3/1 (Dolby Digital)	0L	0R	0C	none	0S	none	none	none
2/1L (Dolby Digital)	0L	0R	none	0LFE	0S	none	none	none
2/1 (Dolby Digital)	0L	0R	none	none	0S	none	none	none
3/0L (Dolby Digital)	0L	0R	0C	0LFE	none	none	none	none
3/0 (Dolby Digital)	0L	0R	0C	none	none	none	none	none
2/0 (Dolby Digital)	0L	0R	none	none	none	none	none	none
1/0 (Dolby Digital)	none	none	0C	none	none	none	none	none
1+1 (Dolby Digital)	0C	1C	none	none	none	none	none	none
PCM	0L	0R	none	none	none	none	none	none

## Technical Functional Overview

Figure 7–1 on page 74 through Figure 7–3 on page 76 illustrate the overall functionality of each of the AMPx-X8 models.

**Figure 7-1 AMP1-D8DA Block Diagram**

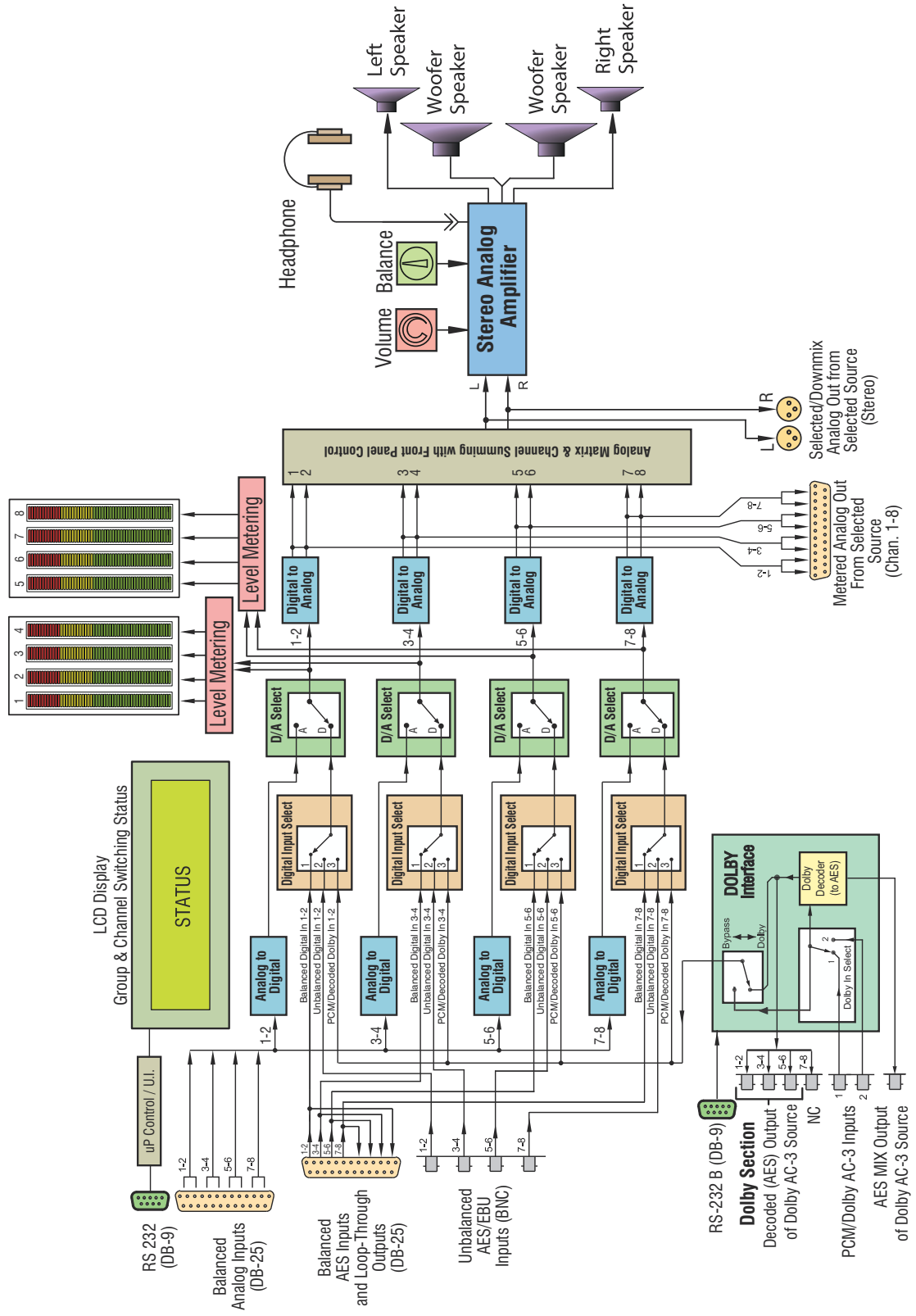

**Figure 7-2 AMP2-D8DA Block Diagram**

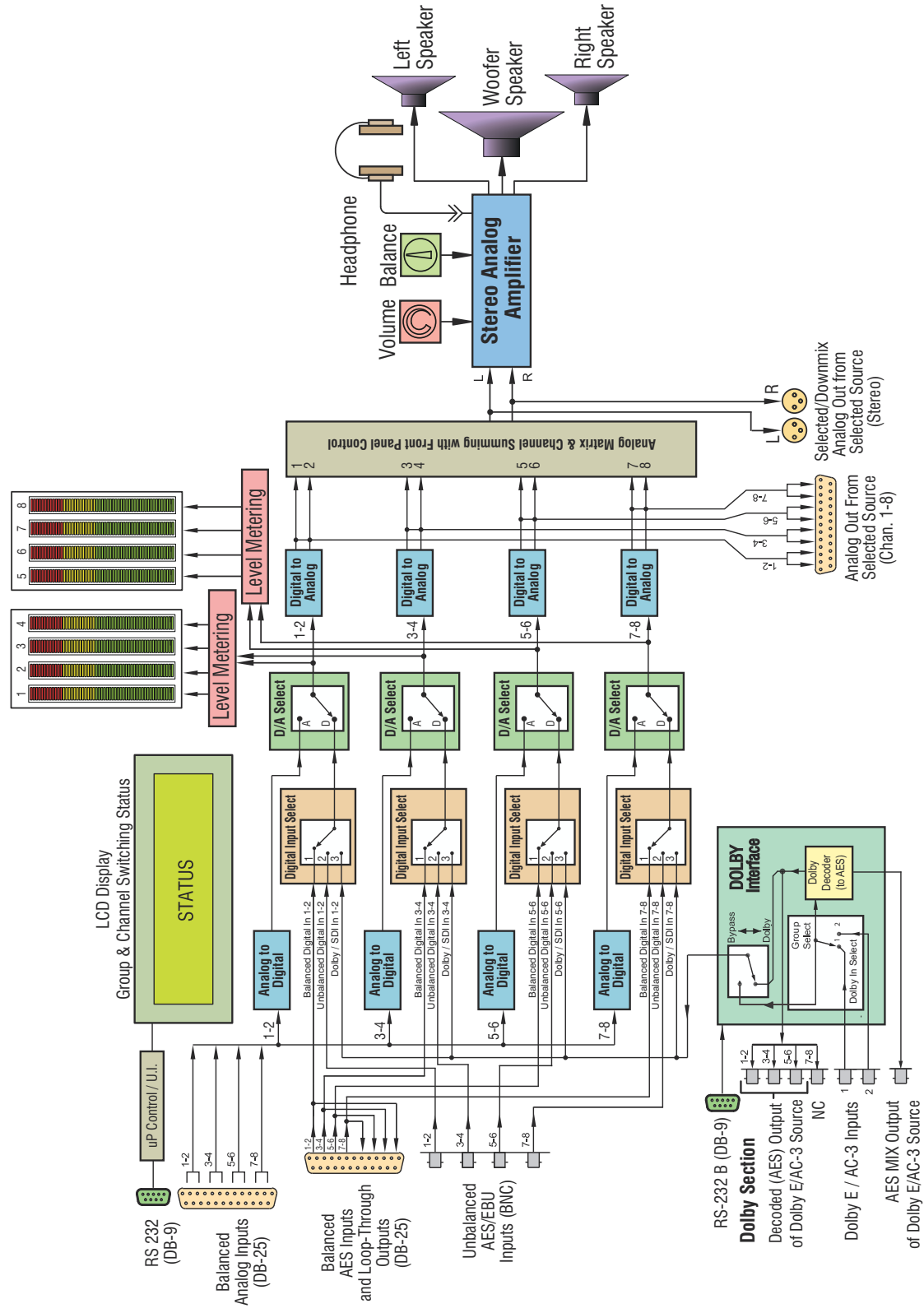

**Figure 7-3 AMP1-D8MDA-3G Block Diagram**

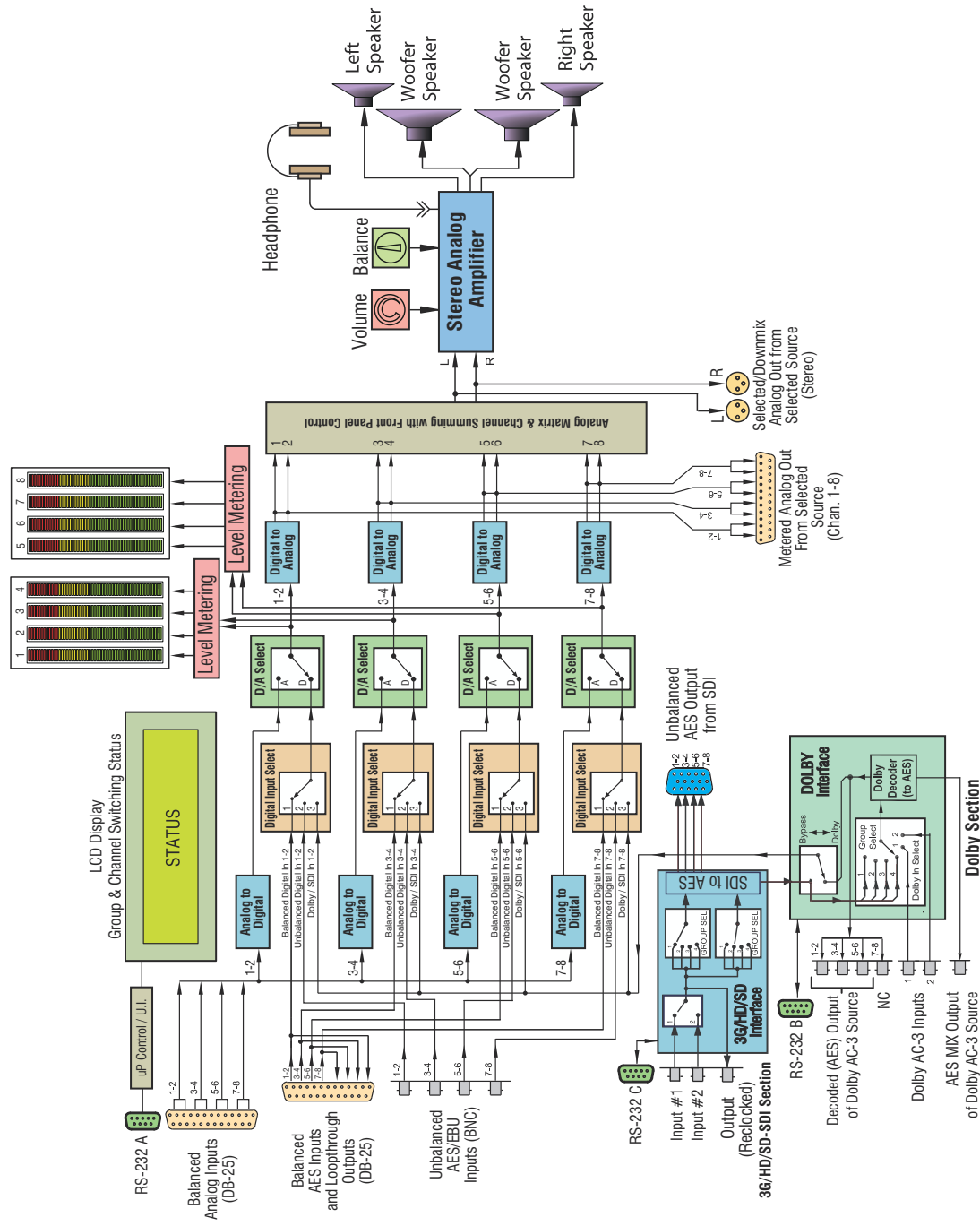

**Figure 7-4 AMP2-D8MDA-3G Block Diagram**

