

RM-4290W-2HD

Dual 9" Dual Input HD/SD-SDI Video Monitors



Full feature set, cost effective, reliable dual 9" video monitor with in-screen audio level meters, vectorscope, and waveform

The RM Series is a highly-featured, low-cost range of in-rack HD/SD-SDI and CVBS video monitors ideal for the many feeds in mobile trucks, news and transmission control rooms, duplication, and post production applications.

These tilting monitors come standard with in-monitor level metering, selectable video waveform and vectorscope, safe and title markers, labeling, tally, timecode, video format, and built-in color bars, as well as familiar CRT-style picture controls and an intuitive on-screen configuration menu.

Input signals are automatically detected and up to 8 of the 16 audio channels embedded in an HD/SD-SDI bitstream may be selected for visual monitoring on 8 on-screen bar graph style level meters on the HD and 2HD models. A headphone jack provides audible stereo monitoring of selected left and right channels.

Rear Panel

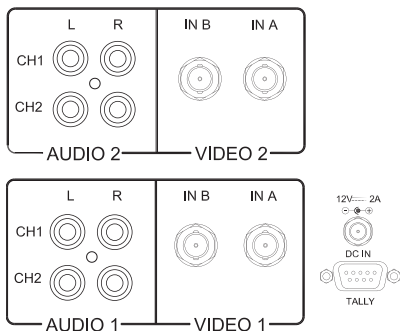

Each of the two high-resolution LCD screens display high-definition or standard-definition video at either 16:9 or 4:3 aspect ratio. Parameters are selected and adjusted using an on-screen display menu.

Benefits:

- User defined hot key functionality provides either H/V delay, underscan, on-screen display, and more
- On-screen level meters provide confidence audio monitoring
- Tally and on-screen labeling provide quick and easy signal identification
- CRT-style image controls allow video image enhancement for each screen individually

Features:

- In-picture level metering, waveform, and vectorscope display
- Labelling, tally, timecode, detected video format, safe area and title markers display
- Gamma color calibration
- Built-in color bars
- User-defined function buttons
- Intuitive on-screen menu
- Headphone output



Order Part Numbers:

RM-4290W-2HD: 8001-0080

RM-4290W-2HD

Dual 9" Dual Input HD/SD-SDI Video Monitors

Block Diagram

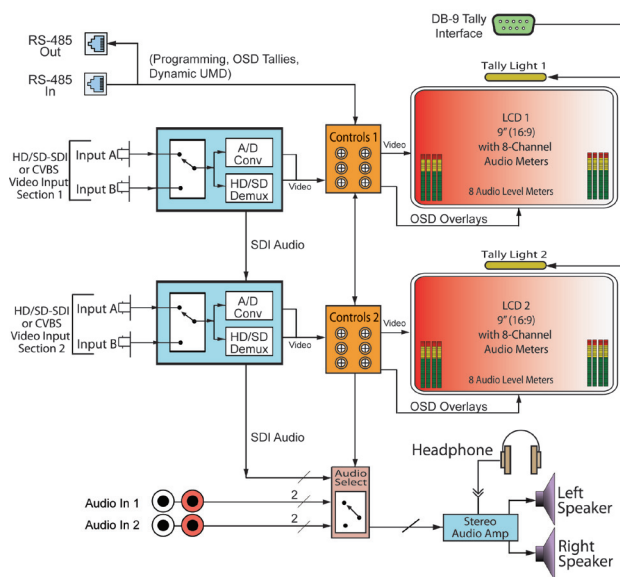

RM Series In-screen Features

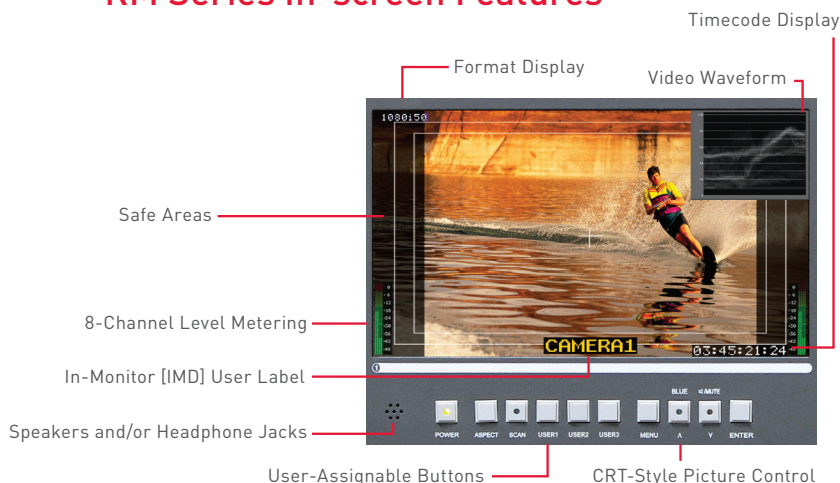

Inputs

- 4 Auto-Sensing HD/SD-SDI, CVBS Inputs on BNC (2 per screen)
- 2 RCA Analog Audio Stereo Input Pairs (1 per screen)

Outputs

- 1 Headphone

Specifications

[View complete list of specifications online at wohler.com](http://www.wohler.com)

Dimensions (H x W x D)	7" x 19" x 2" (178 mm x 483 mm x 64 mm)
Shipping Weight / Net Weight	11 lbs (4.9 kg) / 8 lbs (3.6 kg)
Space Requirements	4RU in a standard 19" rack
Accessories Included	AC power cord
Power Connector	AC power adapter (100-240VAC to 12 VDC)
Power Requirements	Power to the unit connects to mains power (100 to 240 VAC \pm 10%, 50/60Hz)
Power Consumption	10W
Display Type	Active color matrix amorphous 9", LCD TFT screens
Display Size	9" Diagonal
Aspect Ratio	16:9 native 4:3 selectable
Active Viewing Area	7.75" H x 4.65" V (196.8 mm H x 118.1 mm V)
Resolution	800 x 480
Luminance	400 cd/m ²
Colors	16.7 million
Contrast	500:1
Pixel Pitch	0.2475 mm (H) x 0.2335 mm (V)
Pixel response	<25 ms off-on-off (black to white to black)

Wohler Technologies, Inc.
Worldwide Headquarters
31055 Huntwood Avenue
Hayward, CA 94544 USA
Phone: +1 510 870 0810
Email: sales@wohler.com

Wohler Technologies/APAC
45/F, The Lee Gardens
33 Hysan Avenue
Causeway Bay, Hong Kong
Phone: +852 8199 0563
Email: sales@wohler.com

Wohler Technologies/EMEA
Suite 3, Medaxon House
Mill Mead, Staines
TW18 4UQ, UK
Phone: +44 (0) 1784 779815
Email: sales@wohler.com

Infinite Possibilities.



One Wohler.